



The CLEANR™ Filter

User Guide (CfWM110)

WARNINGS

IMPORTANT SAFETY INSTRUCTIONS

BEFORE USING THIS PRODUCT, READ ALL INSTRUCTIONS AND SAFETY WARNINGS IN THIS MANUAL.

When using an electrical appliance, basic precautions should always be followed, including the following:



WARNING

These warnings apply to the CLEANR Filter for Washing Machines and, where applicable, to all accessories and power components.

TO REDUCE THE RISK OF FIRE, ELECTRIC SHOCK, OR INJURY:

- This appliance is not intended for use by persons (including children) with reduced physical, sensory, or mental capabilities, or lack of experience and knowledge, unless they have been given supervision or instruction concerning use of the appliance by a qualified person.
- Do not allow children to play with or use this device unsupervised. The device contains small parts and electrical components that could pose hazards.
- Use only as described in this manual. Do not perform maintenance other than as specified or advised by CLEANR support.
- Do not operate the device in wet environments, extreme temperatures, or excessive moisture. Use in dry, indoor locations only.
- Do not operate the device without the CLEANR Filter properly installed. Doing so may result in improper filtration or potential damage.
- Place the device on a flat, stable, and dry surface during use. Ensure it is securely positioned to avoid tipping or water leakage.
- Do not handle the plug, power cord, or device with wet hands.
- Do not use the device if the power cord is damaged. If the supply cord is damaged, it must be replaced by CLEANR approved replacement.
- If the device malfunctions, has been dropped, damaged, or exposed to external water, discontinue use and contact CLEANR support.
- Contact CLEANR support for any service or repair needs. Do not disassemble the device, as incorrect reassembly may result in electrical shock or fire.
- Do not stretch, twist, or place strain on the power cord. Keep the cord away from heated surfaces and do not run it under doors or sharp edges.
- Unplug the device by grasping the plug, not the cord.
- Do not attempt to filter substances other than washing machine wastewater. This device is designed exclusively for microplastic filtration for residential washing machines.
- Do not use the CLEANR Filter with any unauthorized cleaning agents, chemicals, or solvents.
- Keep hair, loose clothing, fingers, and body parts away from the device's openings and moving components.
- Do not insert foreign objects into openings. Keep the device free from lint, debris, and blockages which could reduce performance.
- Use only CLEANR-approved accessories and replacement parts.
- Do not modify the device or power components in any way.
- Do not store or operate the device near heat sources, open flames, or combustible materials.
- If overheating, smoke, or unusual smells occur, immediately disconnect the device from power and move it to a safe, well-ventilated area. Contact CLEANR support for further assistance.
- Do not use the device outdoors, in a bathroom, or near water sources such as sinks or pools.
- This device contains electronic components. Dispose of it in accordance with local regulations for electronic waste.

READ AND SAVE THESE INSTRUCTIONS

For more information or assistance, visit <https://www.cleanr.life/> or contact support@CLEANR.life.

DISPOSAL AND WARRANTY

Disposal of Packaging Materials

The packaging materials for your CLEANR device are designed to be recyclable and eco-friendly. Please dispose of cardboard boxes and protective materials in accordance with local recycling guidelines. Ensure that any wrappings, bags, or other packing materials are kept out of reach of children to prevent suffocation hazards.

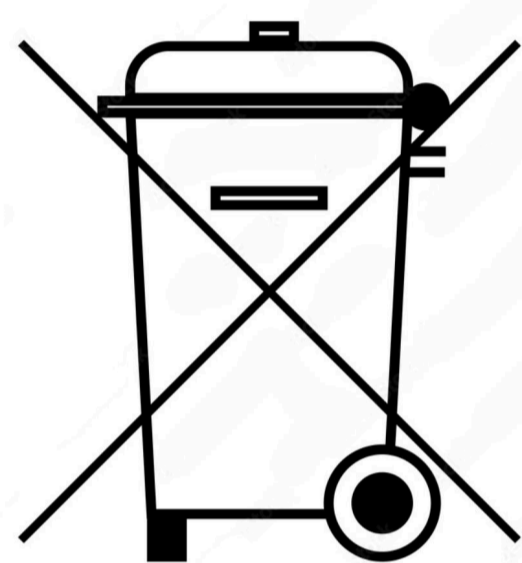

Disposal of Your CLEANR Filter

Electronic devices contain valuable and recyclable materials, as well as components that require proper disposal. Do not dispose of your CLEANR device with regular household waste, as improper disposal may be harmful to the environment. Follow local regulations for electronic waste disposal.

Consult with local waste management authorities or recycling facilities for proper disposal methods. CLEANR assumes no responsibility for data or information stored on any smart-enabled devices. Ensure the device is kept away from children until proper disposal.

Electrical Operation

Voltage 100-240v | Frequency 50-60 Hz | Max Power 72W

Certifications



This product fulfills the requirements of: UL 979, IEC 60335-1: 2020, EN IEC 60335-1:2023+A11:2023, EN 62233:2008, AS/NZS 60335.1:2020 + A1:2021

Warranty

12-month warranty from CLEANR's delivery to its customers (US)

Customer Service: Visit [CLEANR.life](https://www.cleanr.life) for Warranty Terms and more information.

CLEANR warrants its microplastic filter shall be free from defects in materials, workmanship, or general function under normal use for a period of 12 months from the date of purchase. This warranty is limited to the repair or replacement of the defective product, at CLEANR's discretion, and does not cover damages resulting from misuse, modification, improper installation, or normal wear and tear. All products must be registered to activate warranty. All parts must be intact and free from damage to be eligible for warranty coverage. Products can be registered at www.cleanr.life/register/

Table of Contents

Welcome	2
Step-by-Step Installation Guide	3
In the Box	3
Get to Know Your Filter	4
Locate Washing Machine Drain Hose	5
Install Washing Machine Hose onto Filter Inlet	5
Install Outlet Hose onto Filter Outlet	6
Install the CLEANR Pod	7
Insert the CLEANR VORTX	8
Optional Brush Hook Storage	8
Connect to Power and Turn on Filter	9
Connect to CLEANR App	10
Run a Test Cycle	11
Using Your Filter	12
Running your Filter	12
Filter Status Indications	12
Maintenance of Your Filter	14
Changing the CLEANR Pod	14
Cleaning the CLEANR VORTX	16
Deep Cleaning Regimen	17
Troubleshooting & Support	18

Welcome

With your new CLEANR Filter, you are playing a vital part in fighting microplastic pollution. The microplastic pollution problem is becoming more recognized and understood each year, and the CLEANR Filter is a groundbreaking product and important tool in the effort to reduce the amount of microplastic particles released into our water systems from washing machines. This manual contains important information on the installation, use, and care of your CLEANR Filter. Please review this manual to take full advantage of your Filter's many benefits and features.

Textile abrasion through the laundering process is the largest source of microplastic pollution contributing to 35% of the microplastic pollution problem. In fact, a study published in the journal Scientific Reports showed that the washing process can release anywhere from 640,000 to 1,500,000 microfibers per kg of fabric. These microplastic particles can enter the human body through the food we eat, the water we drink, and even the air we breathe. The presence of microplastics in nearly every part of the human body has raised serious concern about the impacts of ingested microplastics on human health.

The CLEANR Filter removes over 90% of microplastic particles as small as 50 microns that would otherwise be washed down the sewer from a load of laundry. To get an idea of just how small the microplastic particles captured by your Filter are, an average human hair has a diameter of about 70 microns; your Filter captures particles even smaller.

With the addition of the CLEANR Filter for Washing Machines to your household laundry routine, you are significantly reducing the amount of microplastics that pour into the environment from your household's laundered fabrics. Thank you for taking action and making a positive impact on the environment.

Feature	CLEANR Premium Microplastic Filter
Industry Leading Microplastic Removal	Removes 90%+ of microplastics down to 50-microns in size certified by The Shaw Institute
Clean, Easy, & Fast User Experience	Change the Pod, the microplastics capture unit that enables proper microplastics disposal, in under 30 seconds, roughly every 5 loads; clean the VORTX usually 1-2 per month
Flexible Filter Placement	Install your Filter on the washing machine or on a surface above / below the washing machine
Wash Your Clothes like Normal	Always finish your load of laundry with no interruption
Know When to Clean	Filter notifies you when it is time to perform cleaning or other maintenance on your Filter
CLEANR App	Pairs with your Filter to provide Filter status alerts right from your smart phone; provides statistics and illustrates the positive environmental impact of your Filter usage in your household laundry routine; also provides ability to purchase Pods right from the CLEANR App.

Installing Your Filter

Step-by-Step Installation Guide

Scan this QR code with your smart phone install the CLEANR app and follow step by step installation instructions

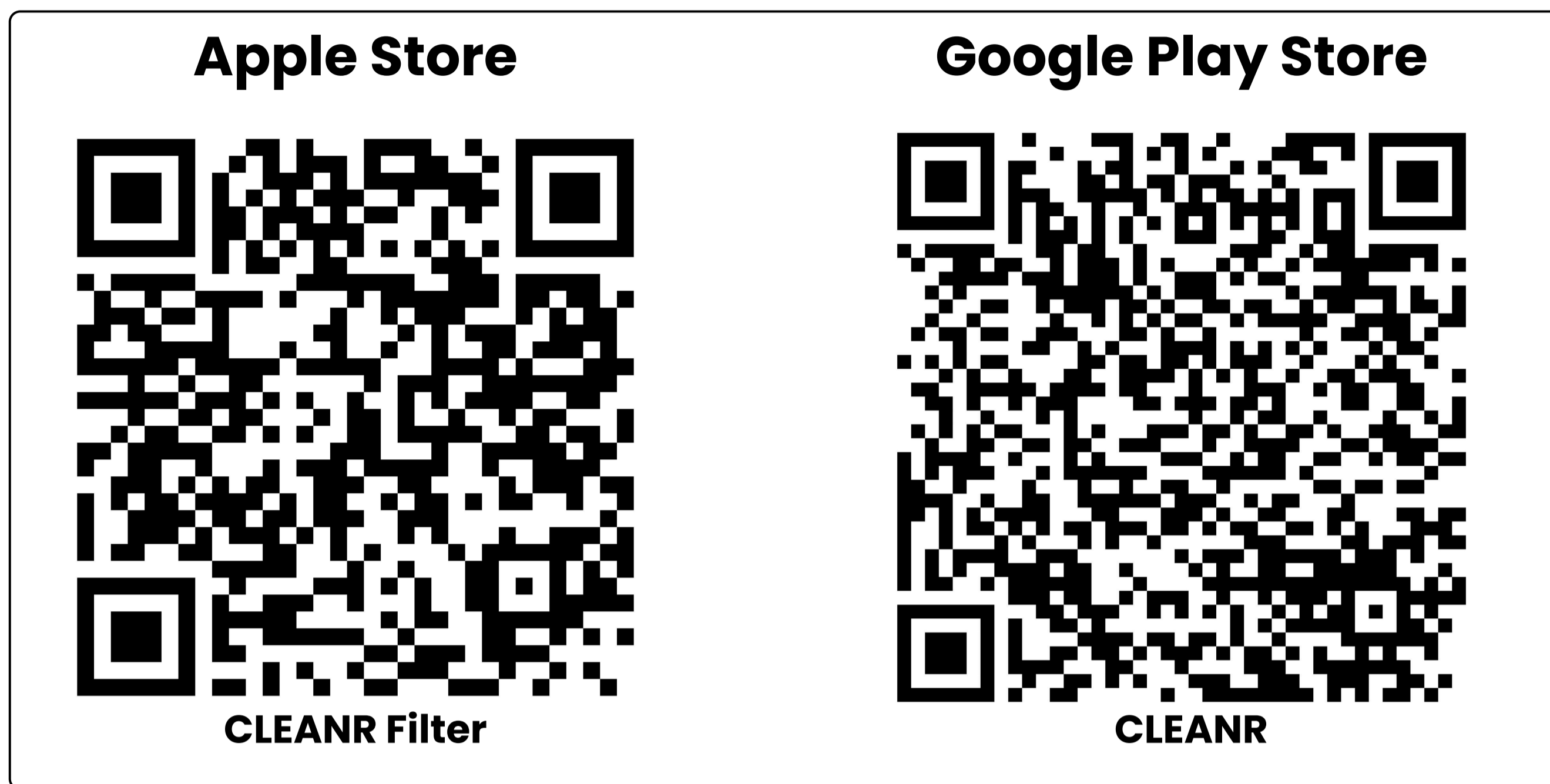

For more installation instructions, go to www.cleanr.life/getstarted

Step 1: Unbox your CLEANR Filter

Included With Your CLEANR Filter

Make sure all the parts are included in the product package. If you have a problem with the CLEANR Filter or are missing parts, contact the support team by emailing support@cleanr.life or by visiting our support page at www.cleanr.life/support.

- A. CLEANR Filter
- B. CLEANR VORTX Filter
- C. Cleaning Brush
- D. CLEANR Pods (10x)
- E. Hose Clamps (2x)
- F. Filter Outlet Hose
- G. Power Cord
- H. Cleaning Brush Hook

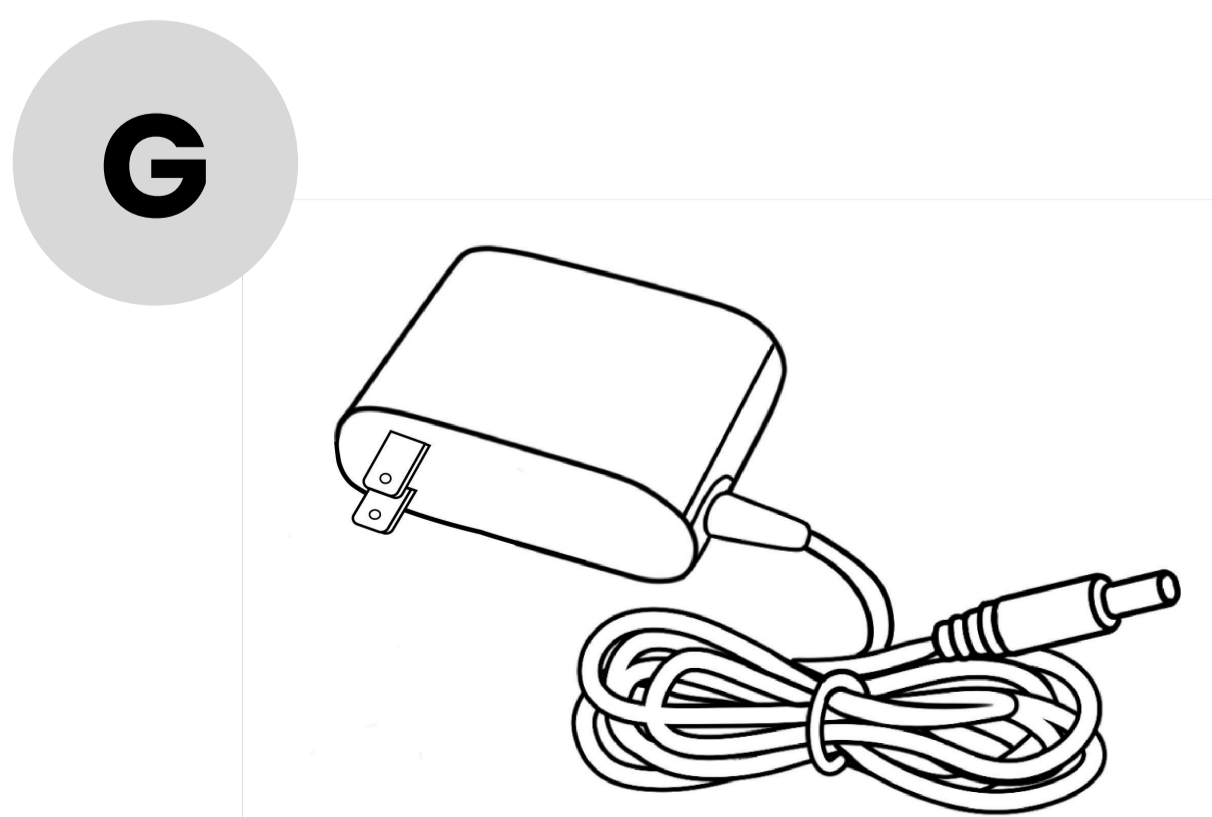
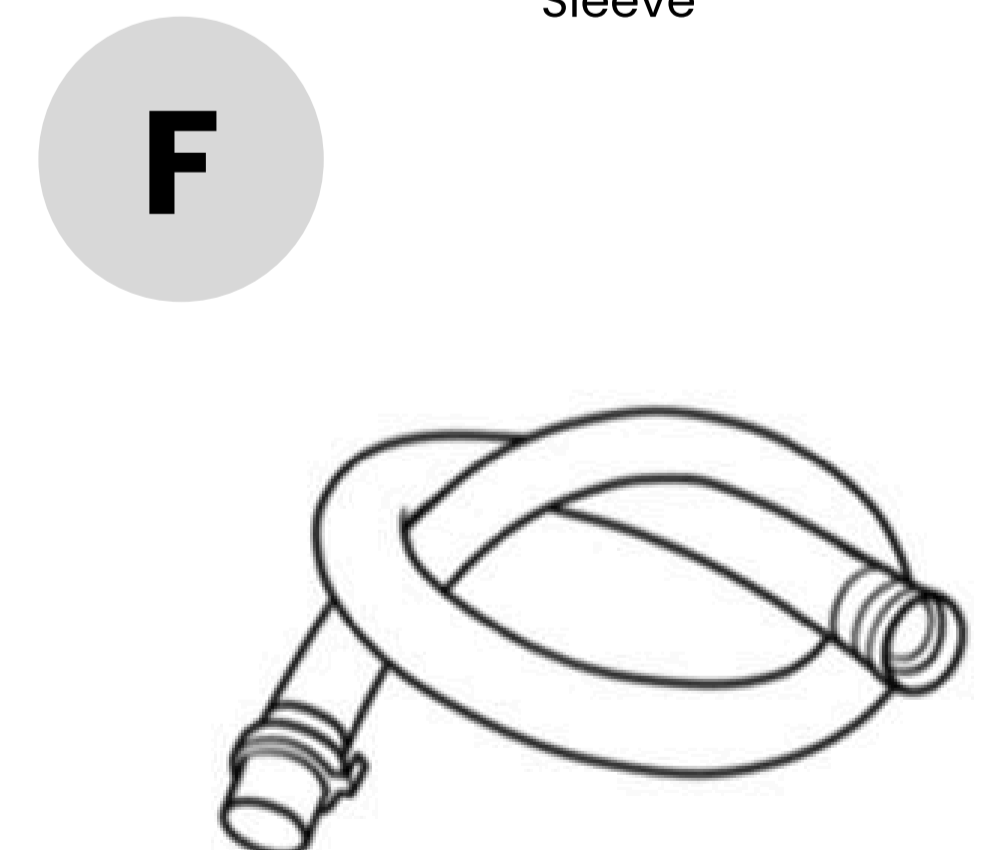
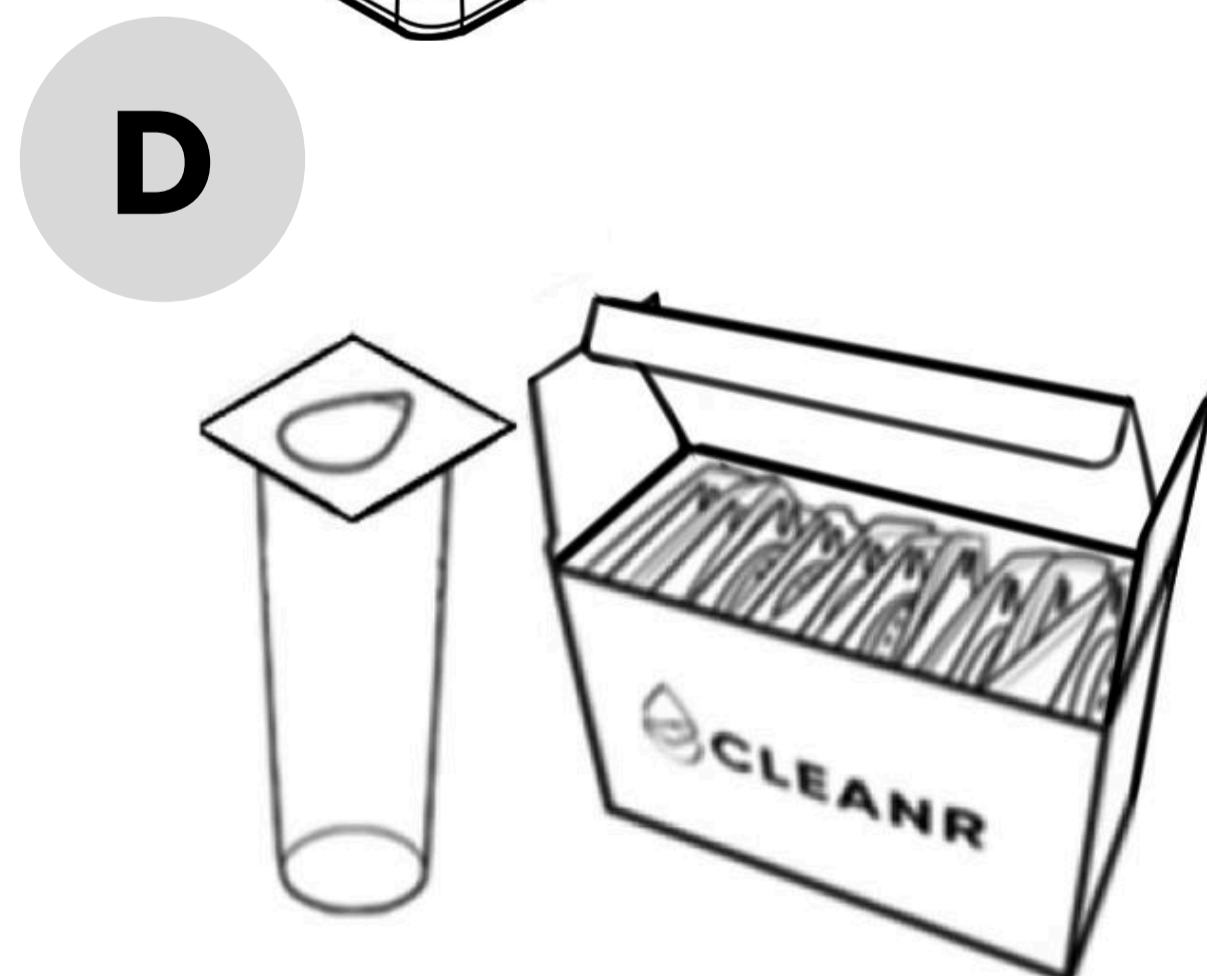
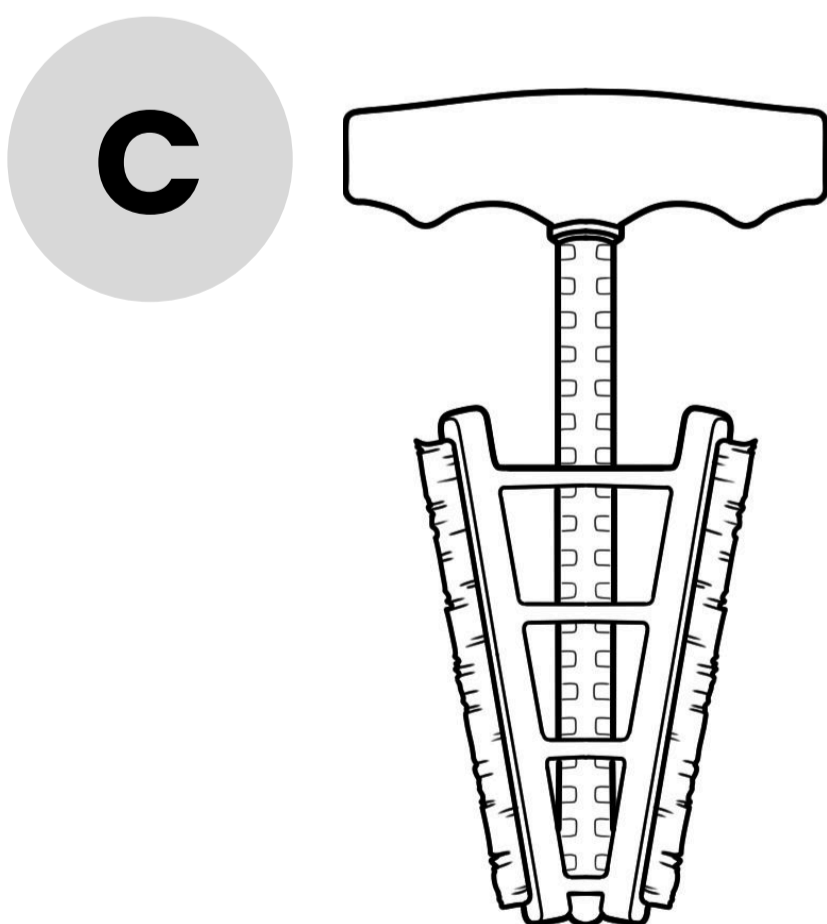
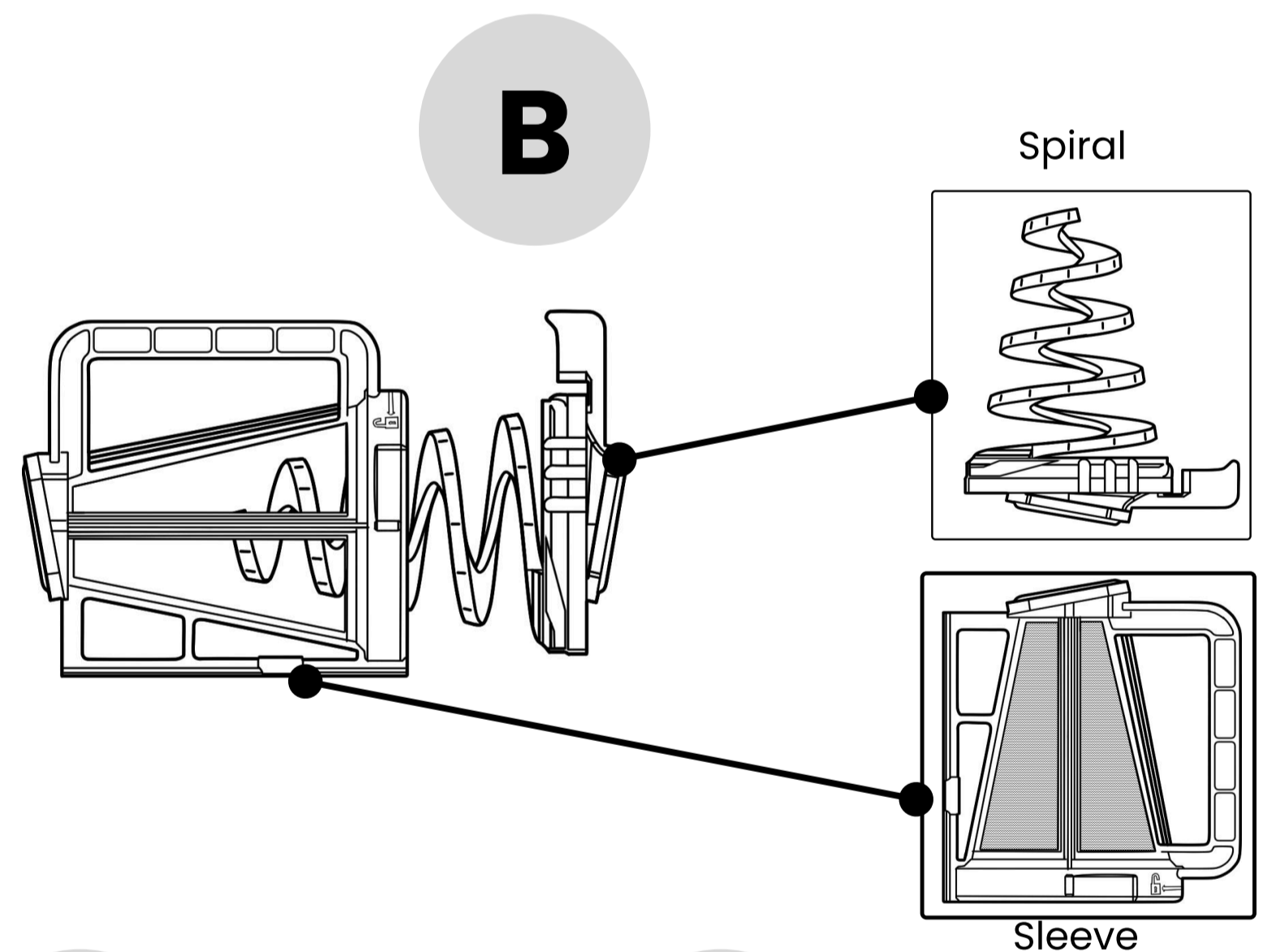
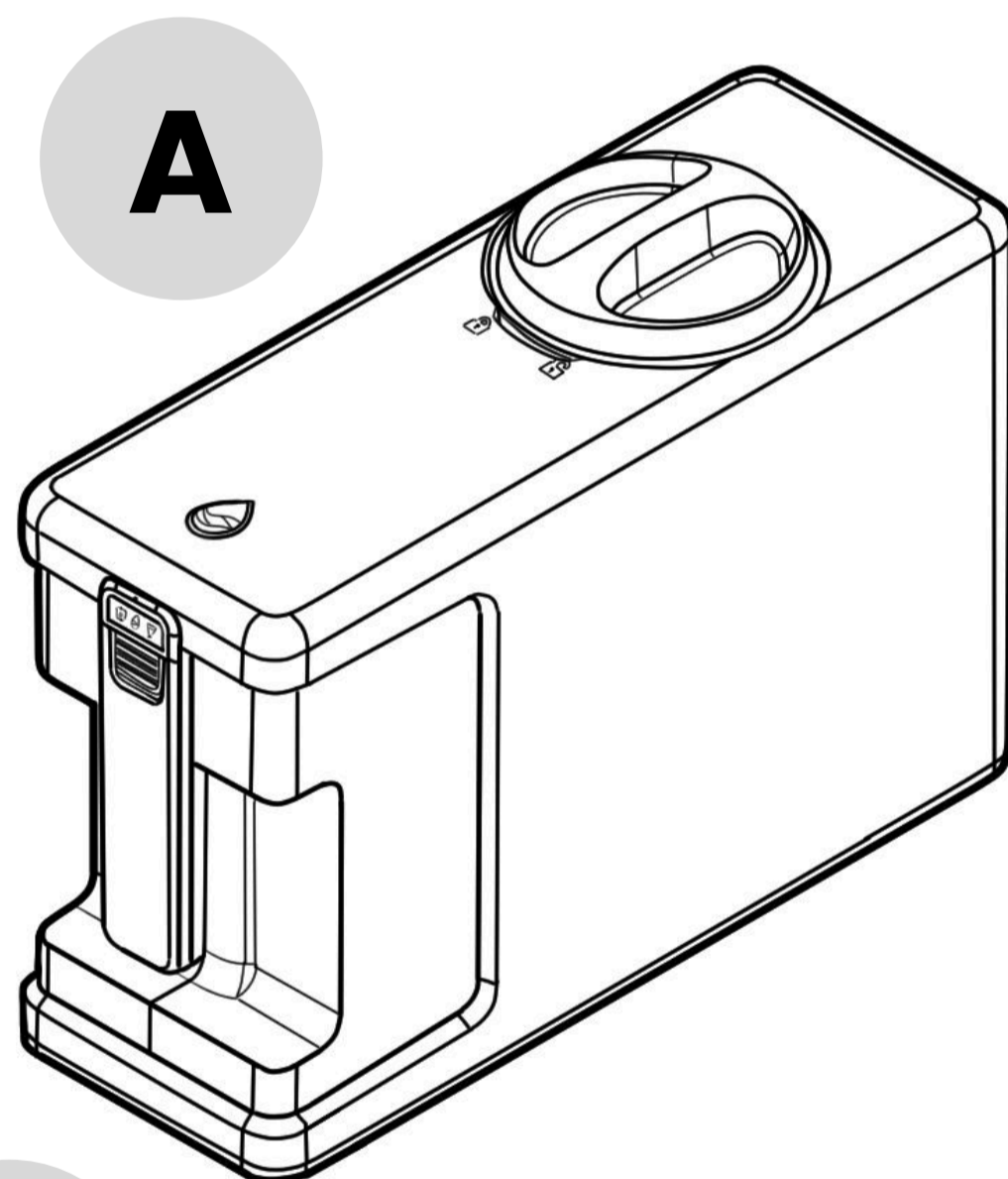

Installing Your Filter

Get to know your Filter and its components:

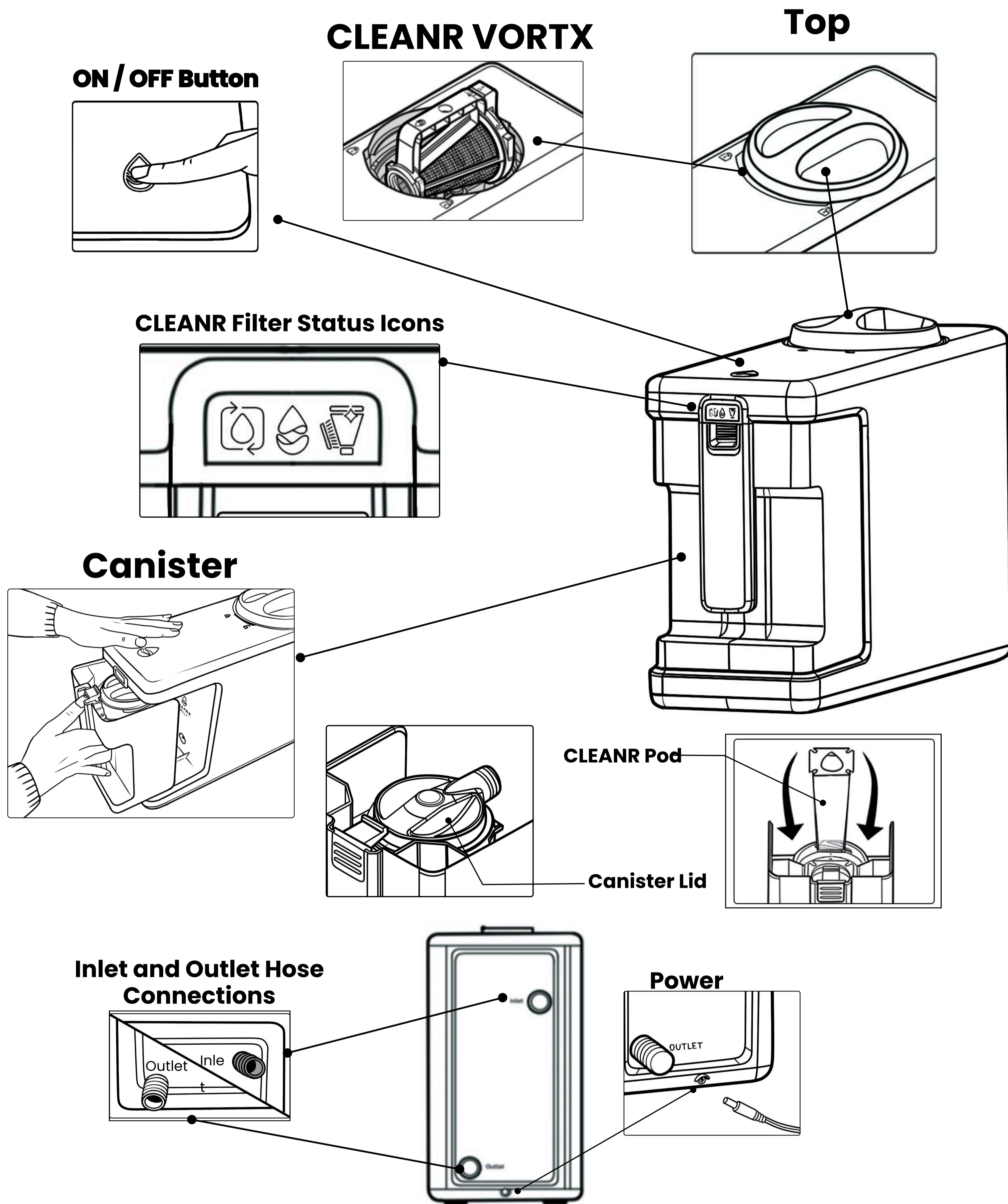

Step 2: Select Installation Location

Before Installation, ensure the washing machine to be connected to your Filter is turned off.

Placement selection

- Choose the surface where you will place your Filter.
 - Select a surface which is flat, level, stable, and free of any water or debris.
 - Ensure the provided power cord can comfortably reach both your Filter and a power outlet.
 - Position the Filter close to ensure it complies with the specified drain height requirements of your washing machine (consult washing machine user manual).
- Place your Filter on the selected surface.

Note: It is recommended NOT to install your Filter on the surface of a top-loading washing machine

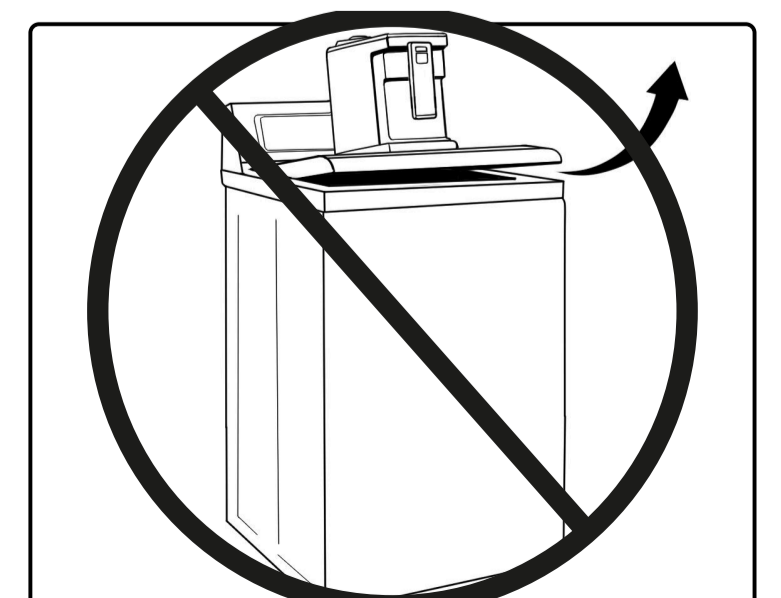

Installing Your Filter

Hose Installation

Hose Installation

To perform the Hose Installation, you will use these parts:

- a. CLEANR Filter
- b. Filter Outlet Hose
- c. 2x Hose Clamps

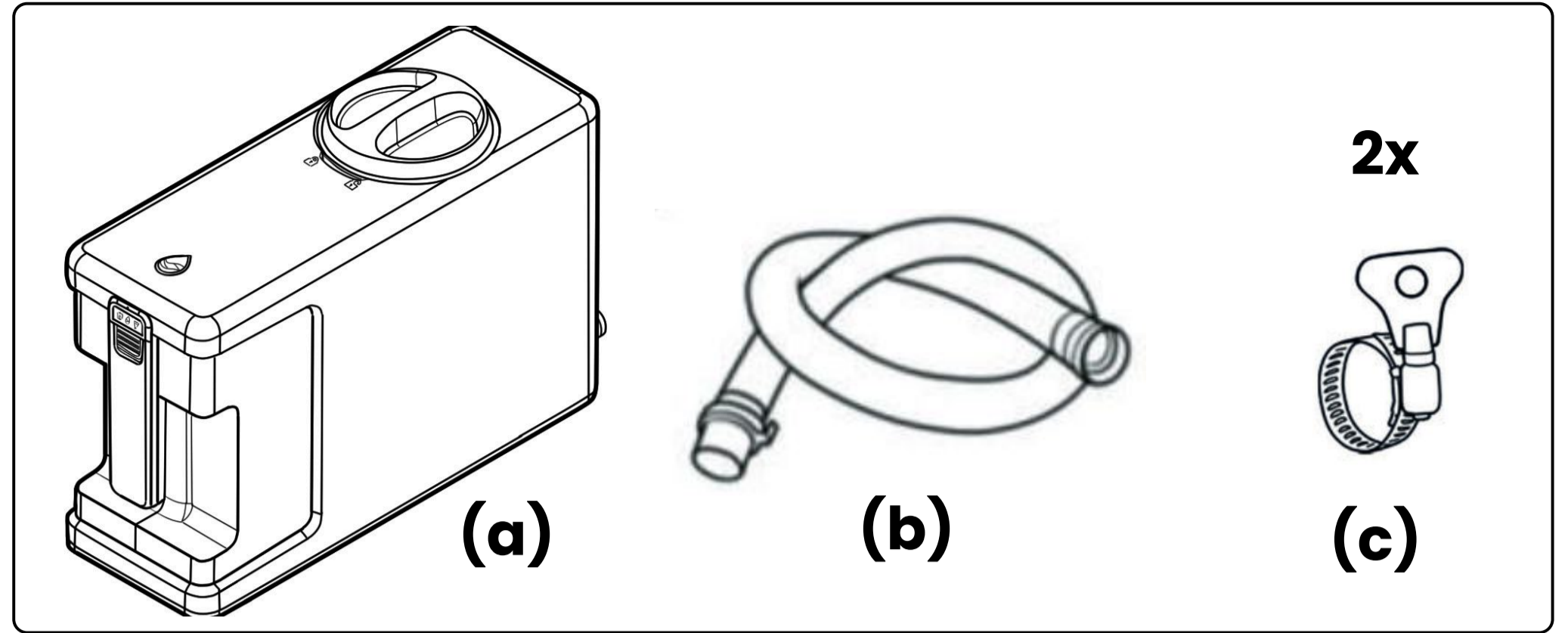

Note: The washing machine does not need to be moved for proper installation. User must locate where the drain hose connects to the drain/sewer/wall.

Step 3: Locate Washing Machine Drain Hose

The washing machine drain hose is typically a ribbed, flexible tube in one of the back corners of the washing machine.

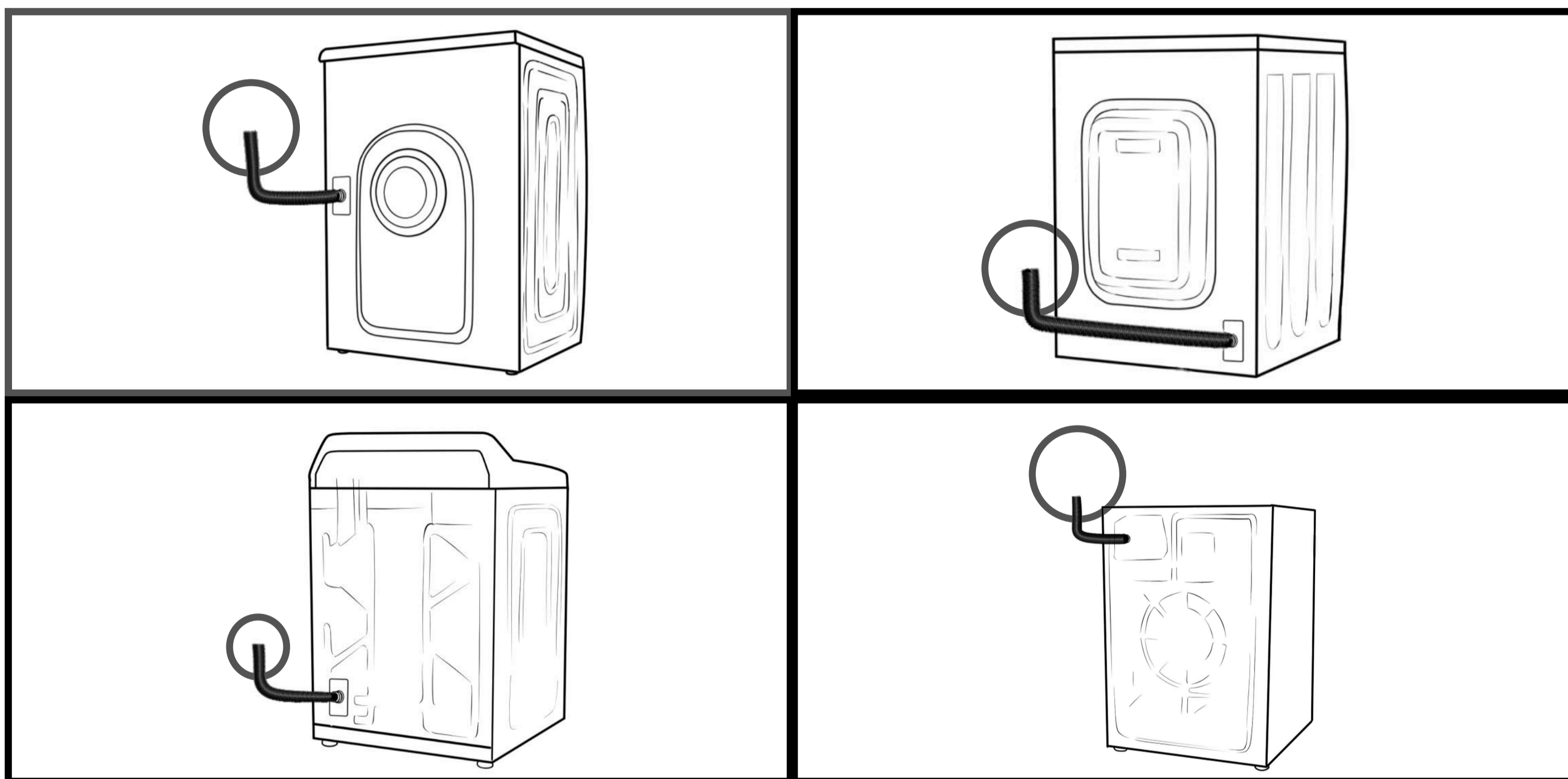

Step 4: Install Washing Machine Hose onto Filter Inlet

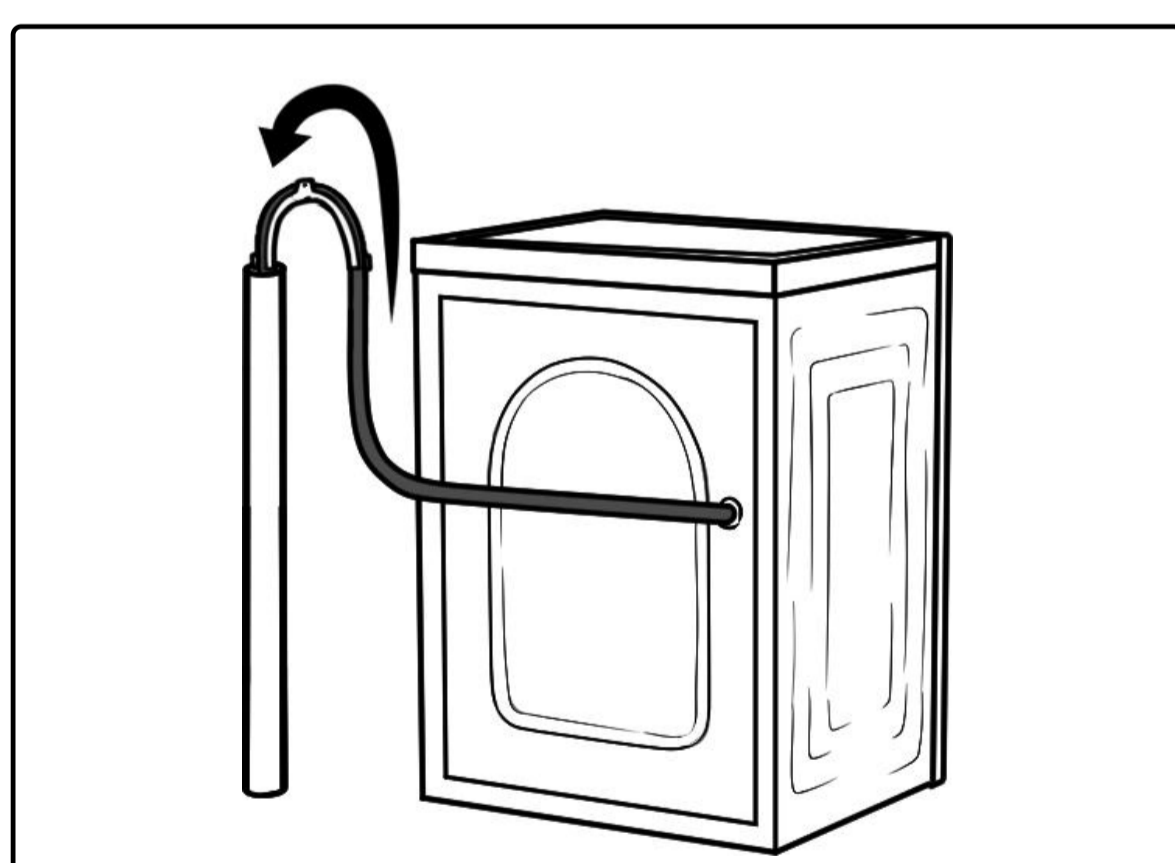

Carefully remove the existing washing machine drain hose from the sewer (there may be some residual water in the drain hose) and clean any debris from the end of the drain hose.

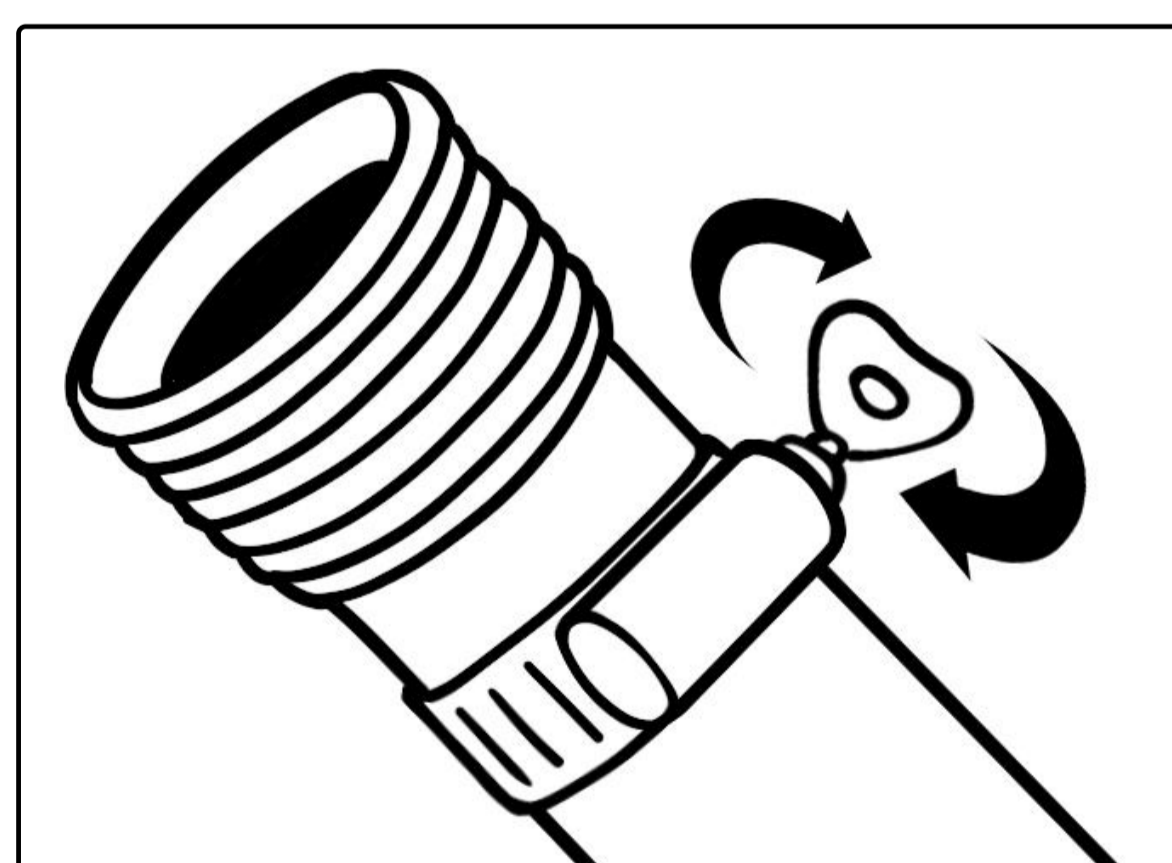

Place one of the provided hose clamps around the disconnected end of the drain hose.

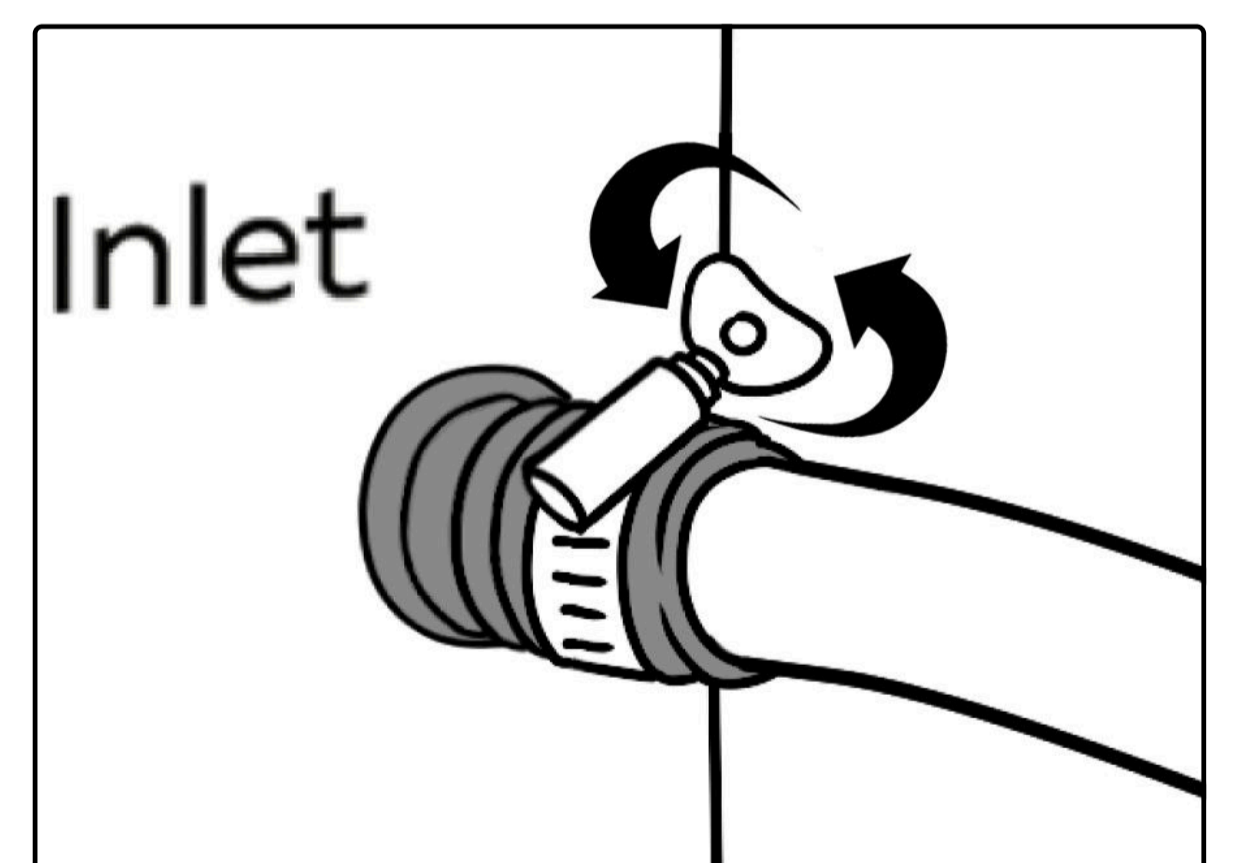

Slide the end of the hose onto the the gray Inlet connection on top of your Filter's back. Position the hose clamp over the connection and twist tight.

IMPORTANT: Hand-tighten the clamp until firm resistance is felt, then add two additional turns to ensure a proper seal.

Installing Your Filter

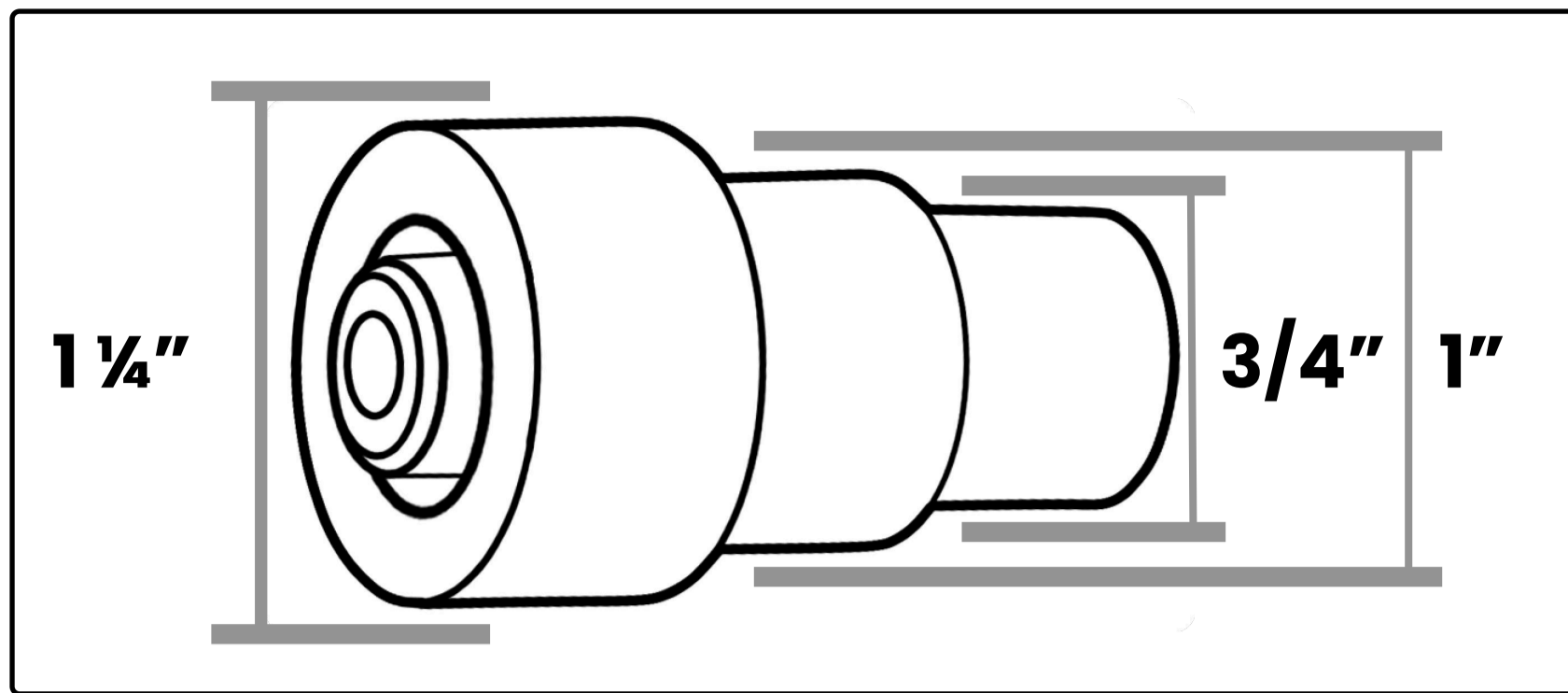

Note : CLEANR Filter Inlet accepts the majority of washing machine hoses. If you have a non standard washing machine hose size, please reach out to our service team on simple ways to connect your Filter

Step 5: Install Outlet Hose onto Filter Outlet

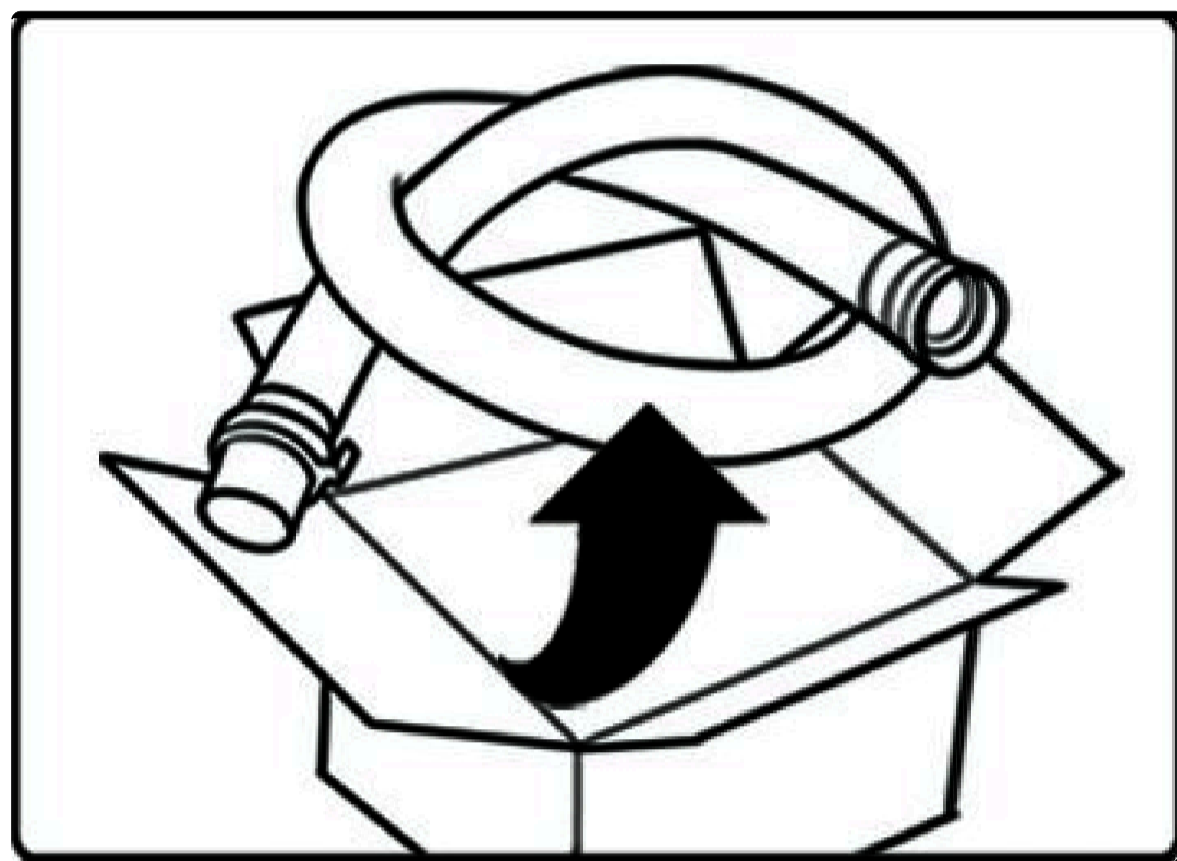

Retrieve the Filter outlet hose included with your Filter.

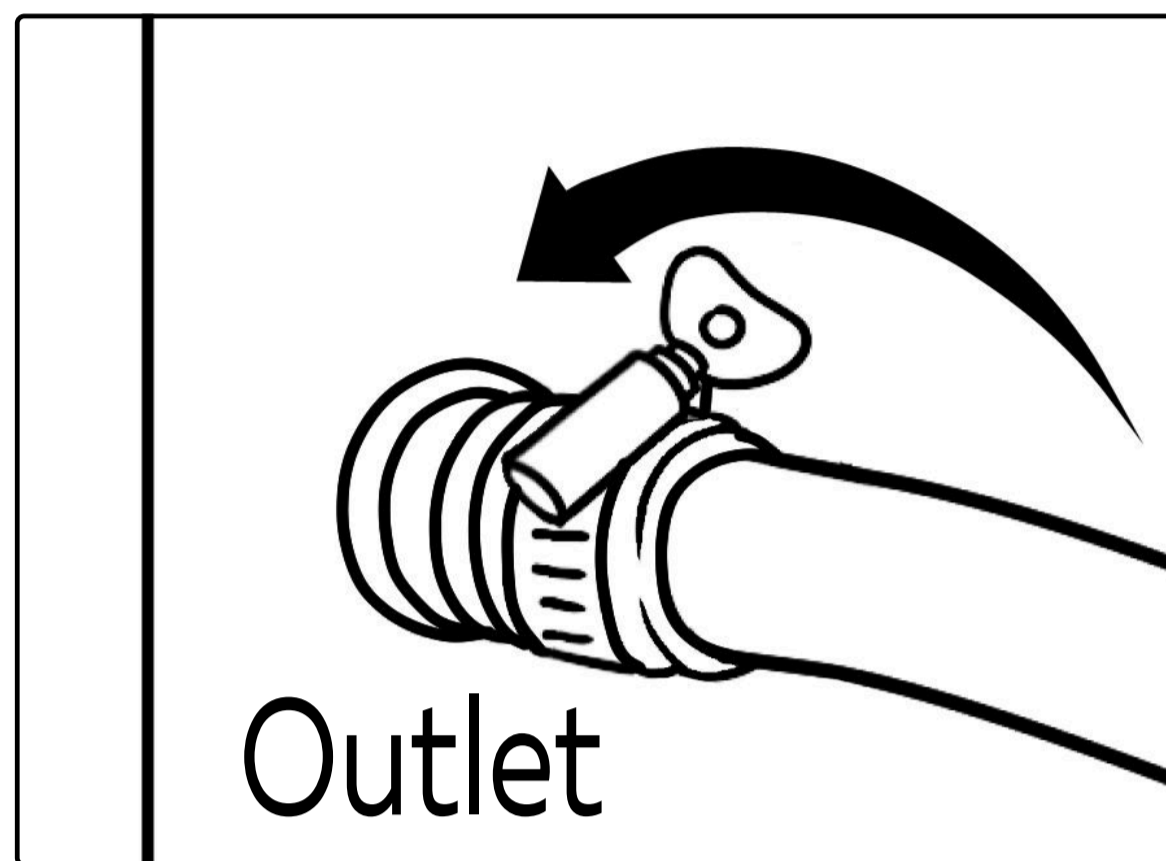

Place the second provided hose clamp around one end of the Filter outlet hose. Slide that end onto the white Outlet connection on the bottom of the Filter's back. Position the hose clamp over the barb and twist tight.

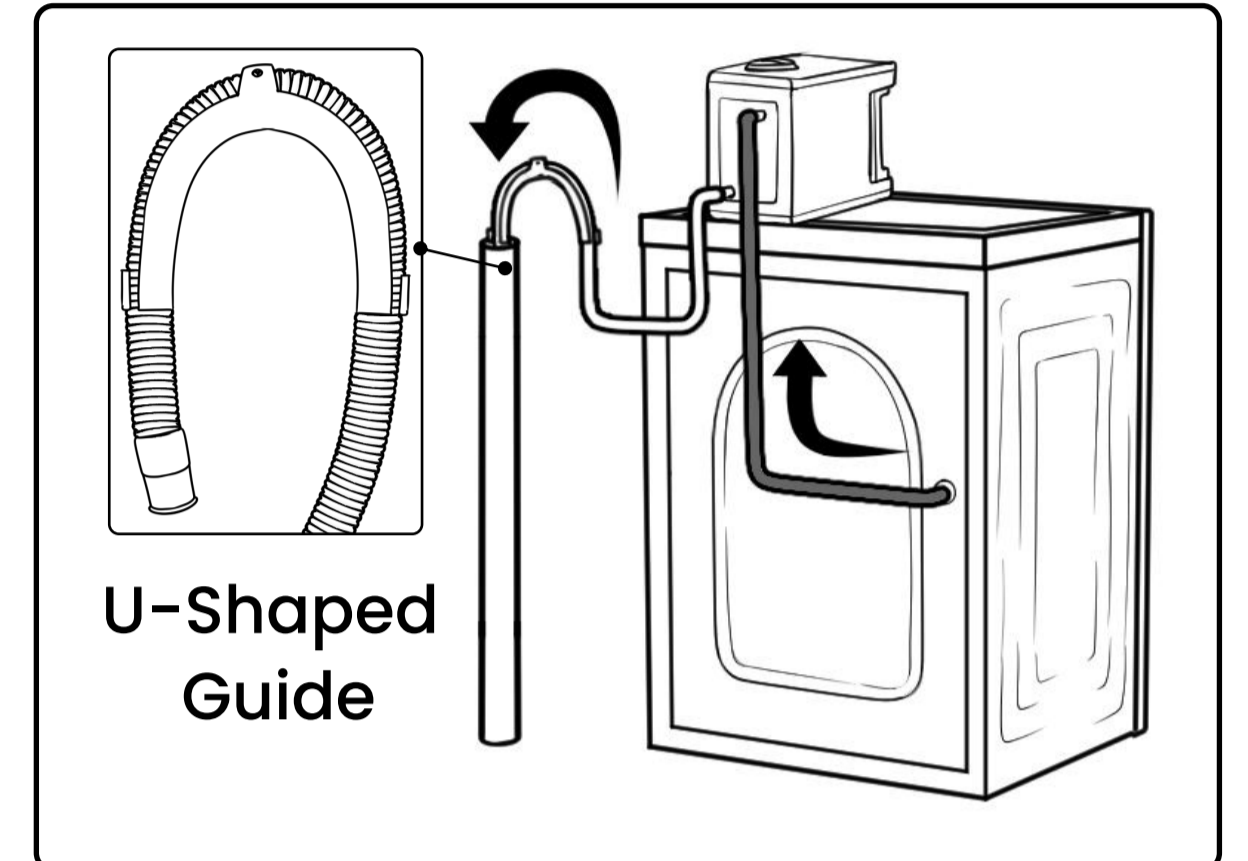

Attach the opposite end of the outlet hose into the laundry sewer. This end of the hose should include the U-Shaped guide. Hose should extend 4.5" into the drain tube.

IMPORTANT: Hand-tighten the clamp until firm resistance is felt, then add two additional turns to ensure a proper seal.

Note: The outlet hose comes with an attached zip tie, which should be connected to the incoming water to prevent the hose from dislodging from the laundry sewer.

Examples of Laundry Sewer/Drain Configurations

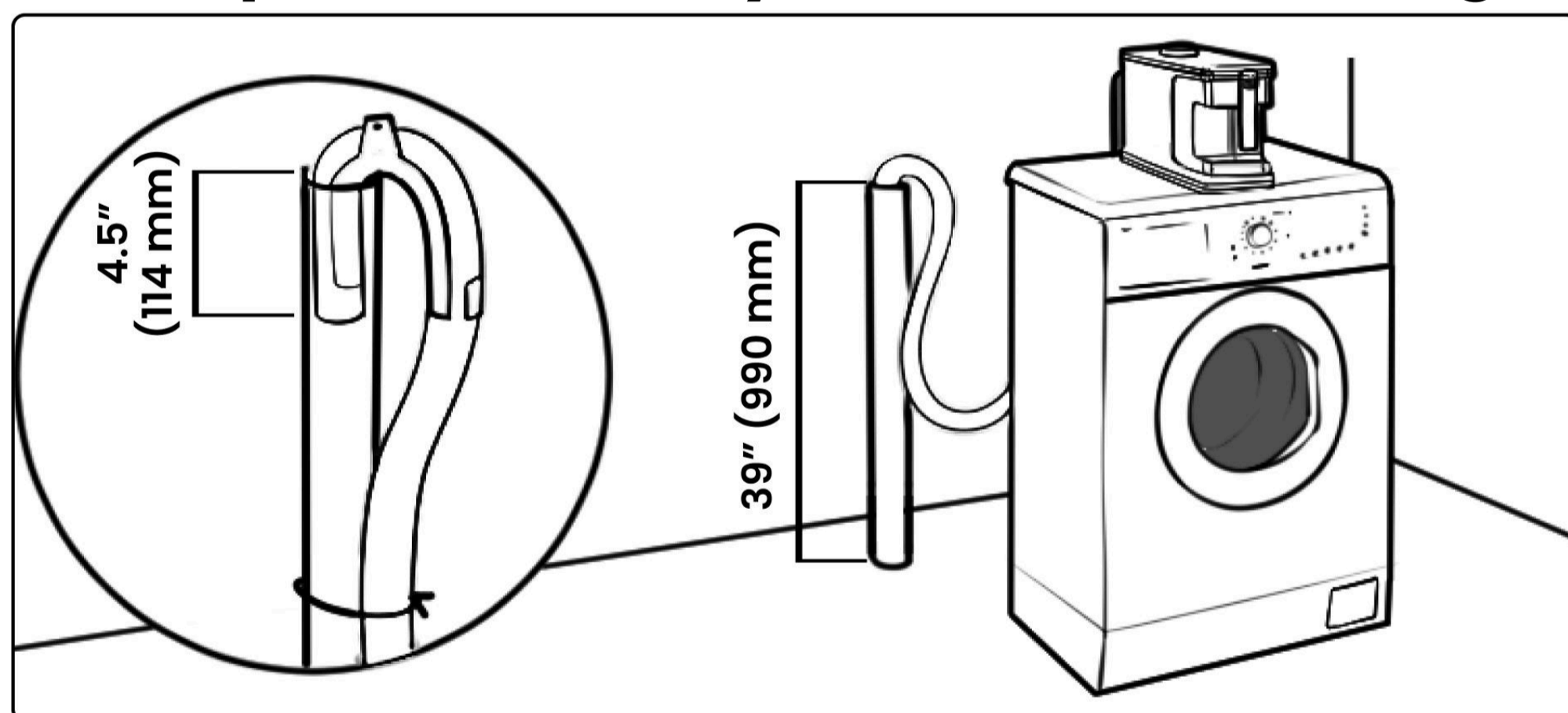

Floor Standpipe

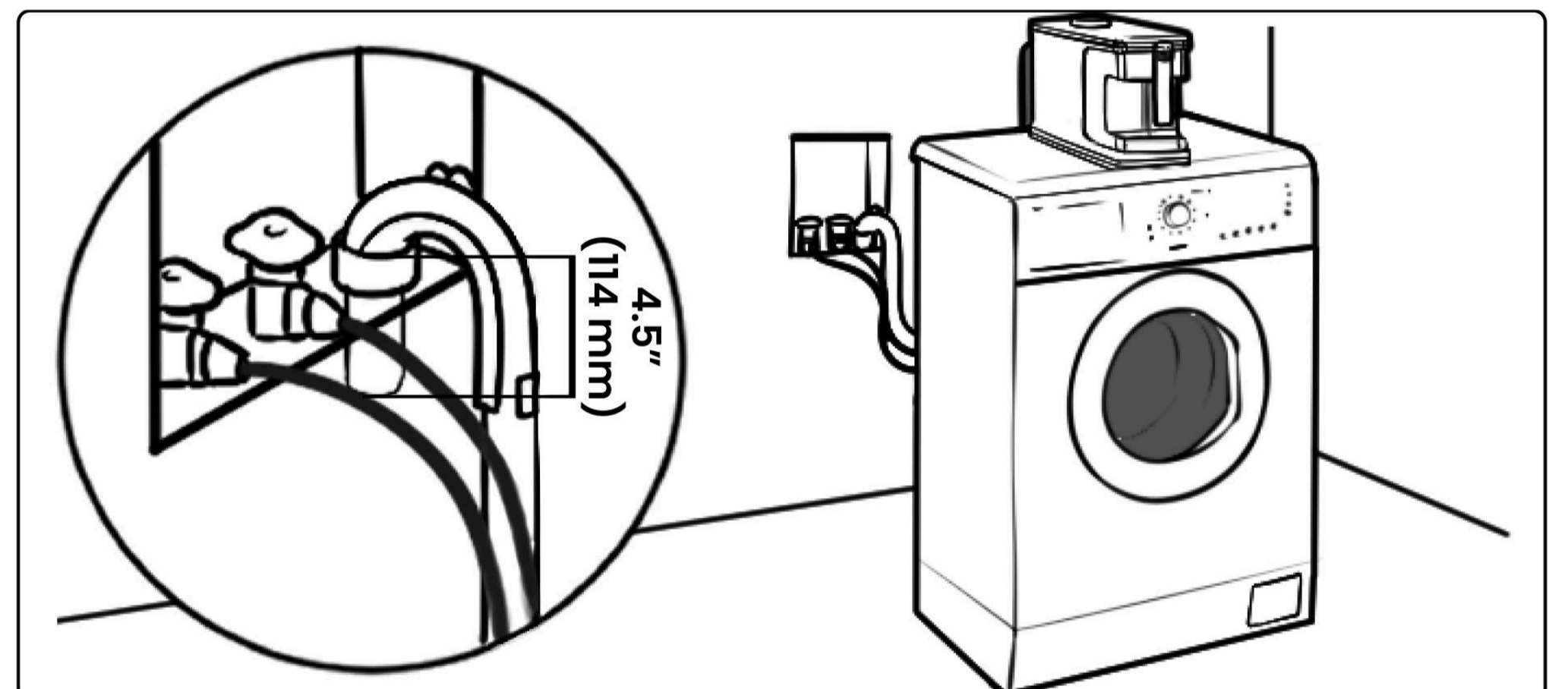

Wall Standpipe

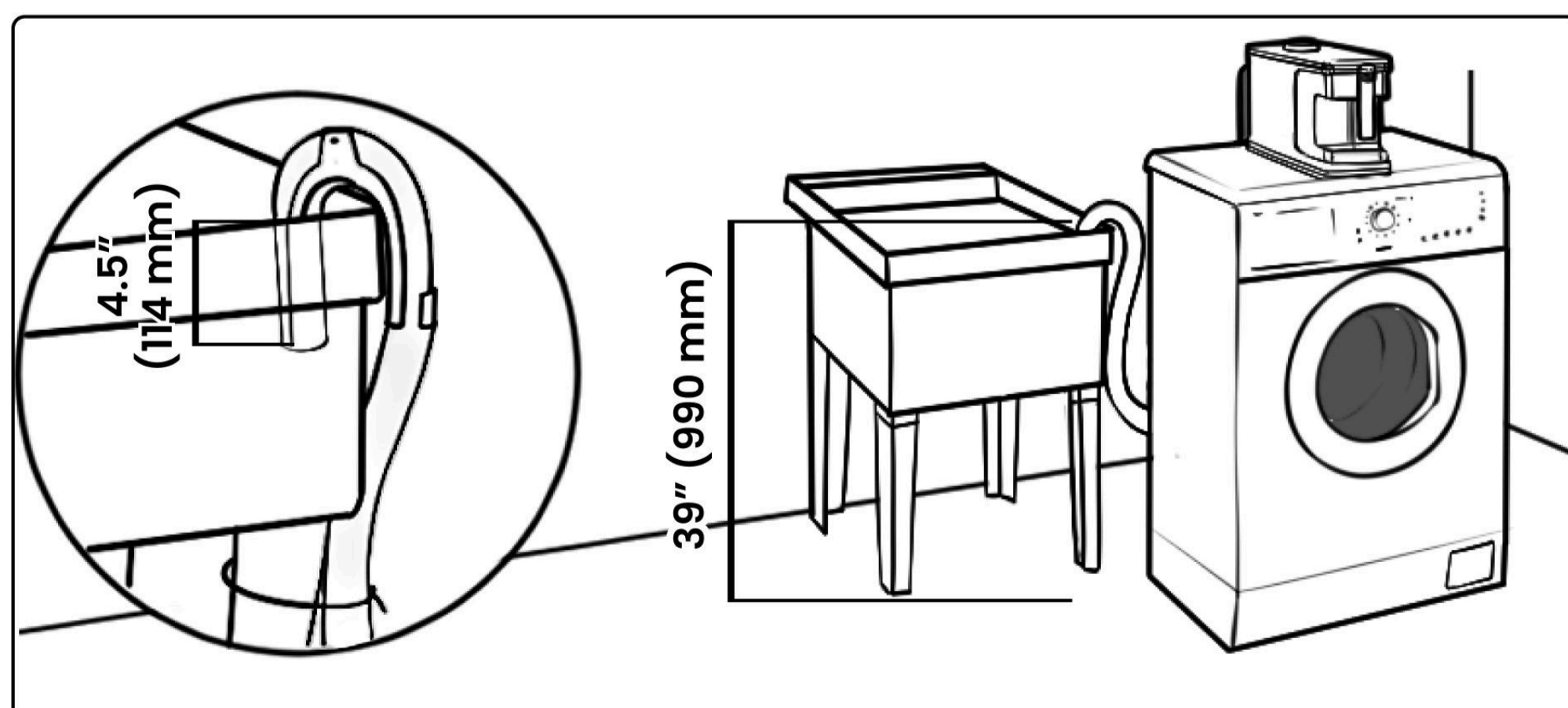

Laundry Tub

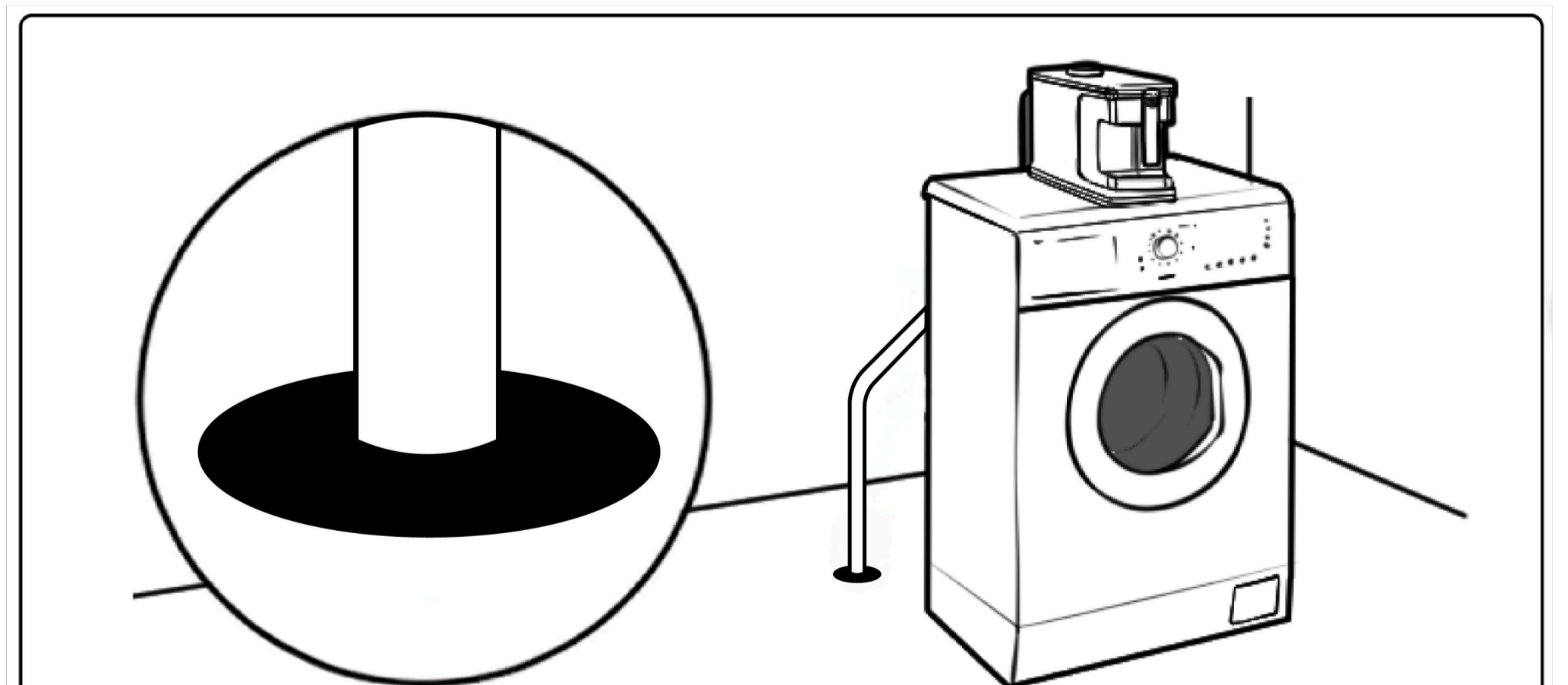

Floor Drain

IMPORTANT: Ensure the hose is placed far enough into the laundry sewer (4.5") and tightly fastened, so that water will not leak or splash out when the washing machine and Filter are running.

IMPORTANT: Check both of the hoses and ensure they are firmly secured and there are no kinks or blockages obstructing the hoses.

Installing Your Filter

Step 6: Install the CLEANR Pod

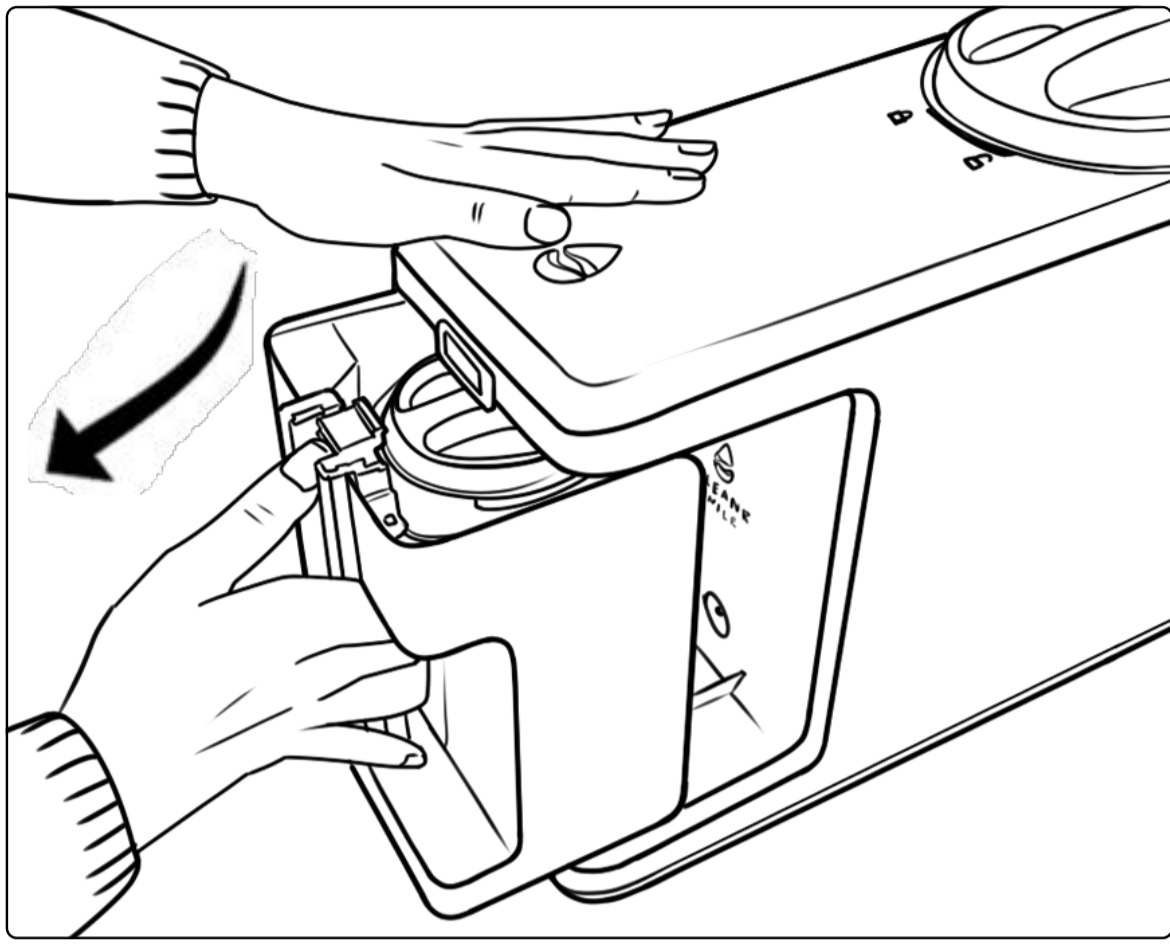

Press down on the canister button. Then pull in the direction of the arrow (as shown in the figure above) to remove the canister.

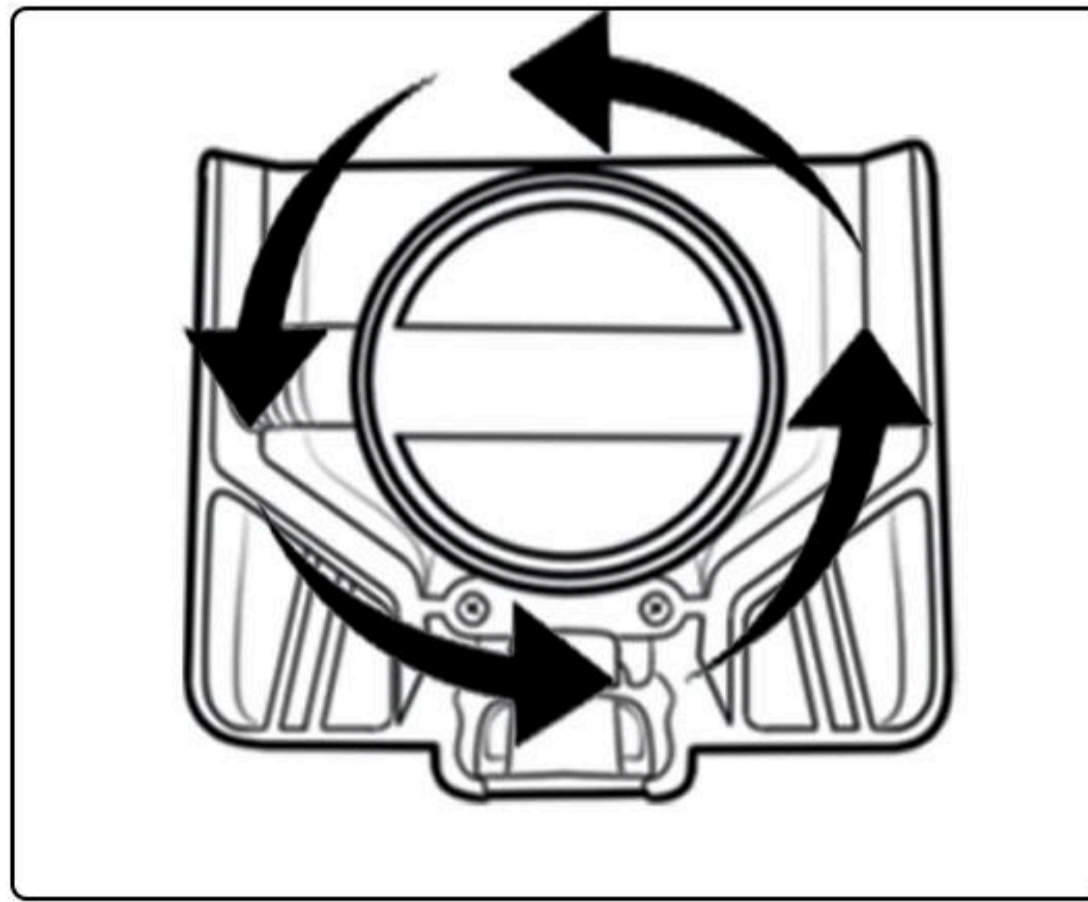

Twist off the canister lid, turning counterclockwise to open, then lift the lid to reveal the location where the Pod will be inserted.

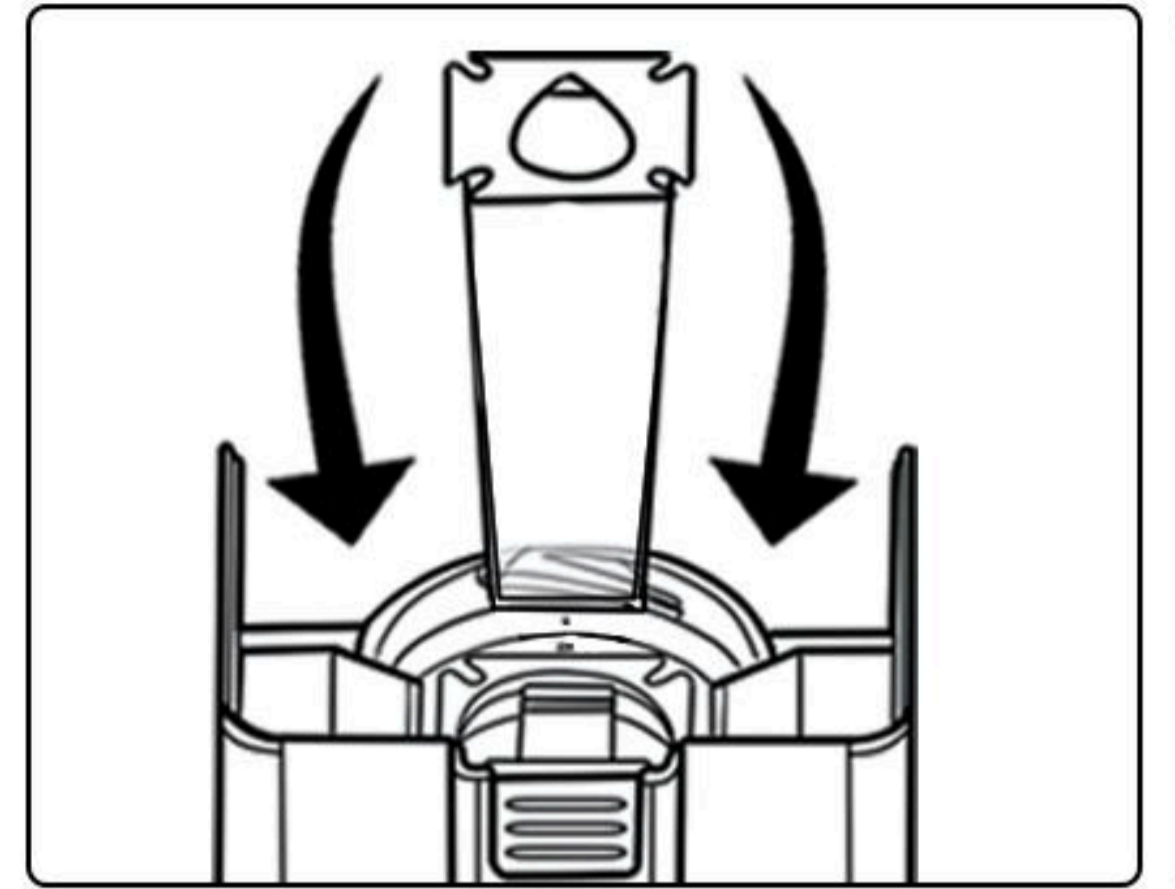

Fit a new Pod into the canister, lining up the corners of the Pod with the notches in the canister until the face of the Pod sits flush with the top of the canister.

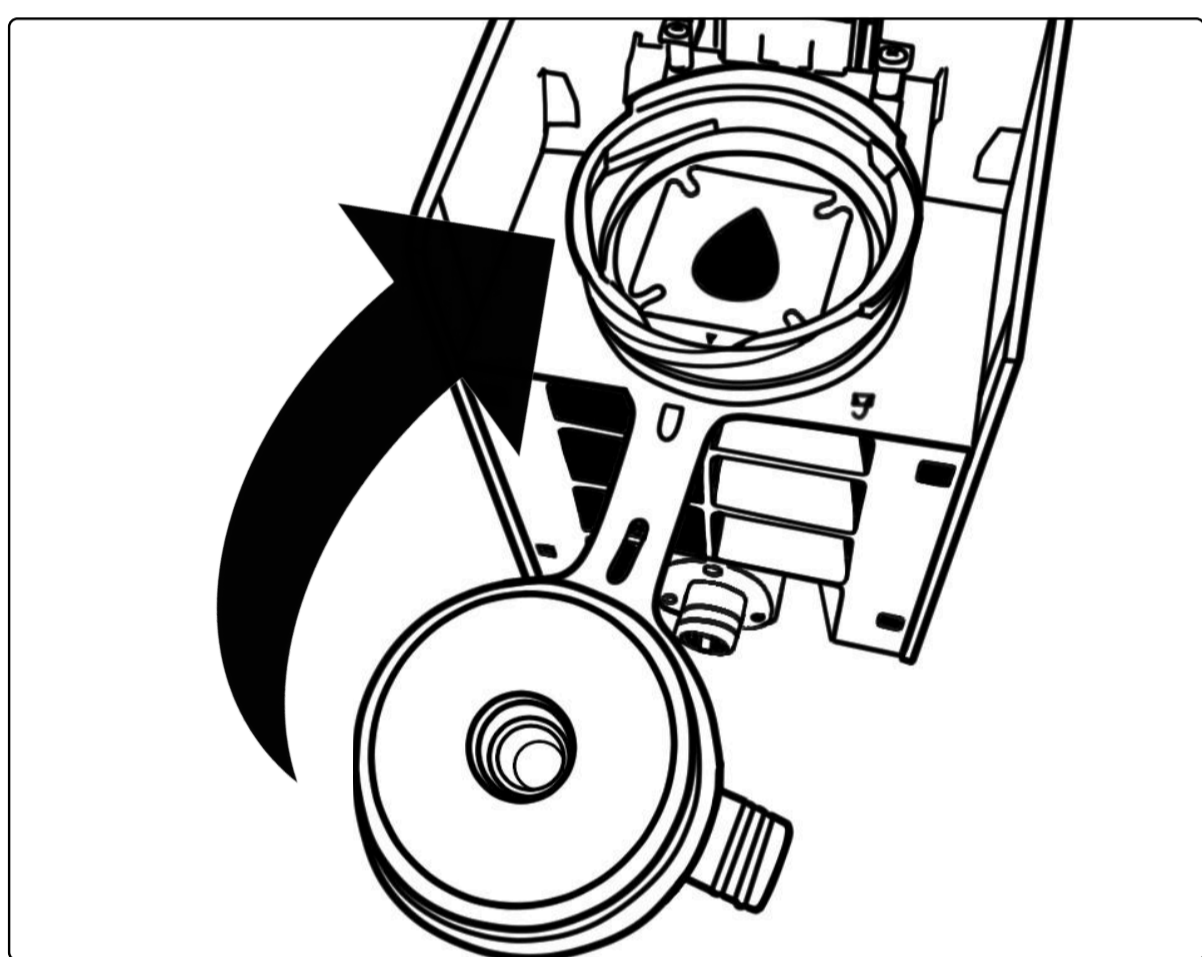

Put the canister lid back onto the canister, positioning the alignment indicator on the canister lid to point to the UNLOCK symbol on the top of the canister.

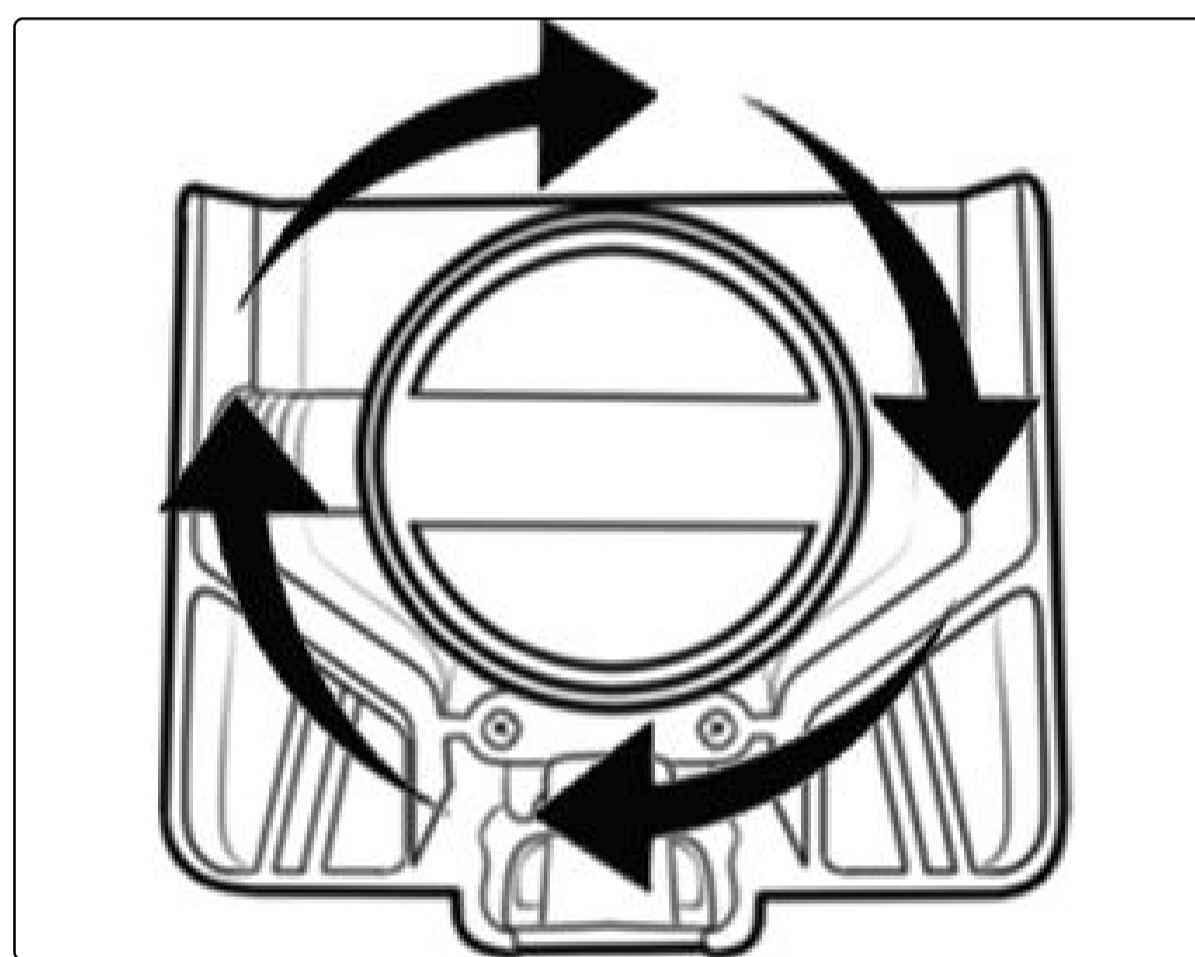

Turn the canister lid clockwise until the alignment indicator on the canister lid points to the LOCK symbol on the canister and the canister lid will not turn any further.

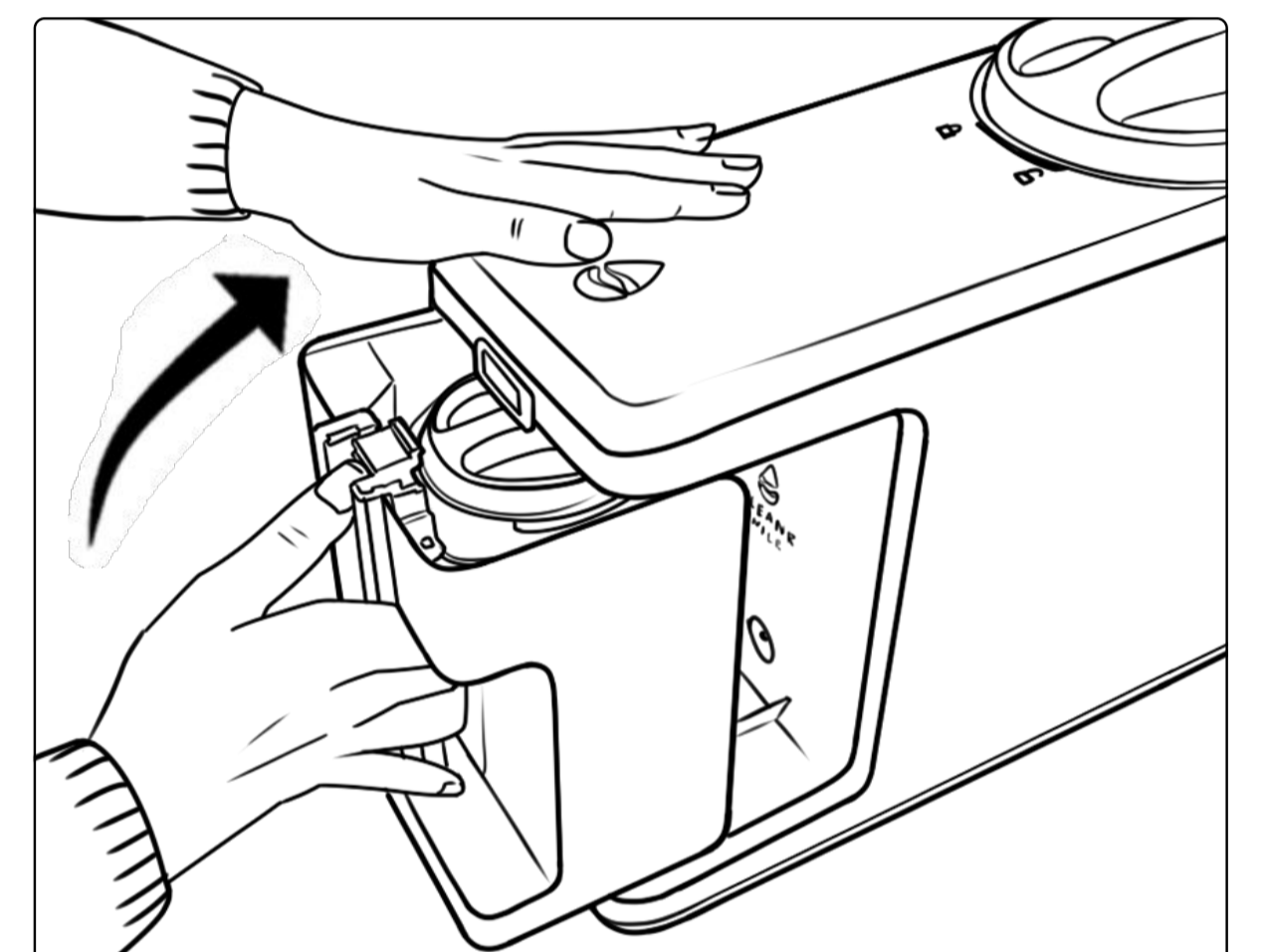

Push down on the canister button while sliding canister back into place until the canister locks into place.

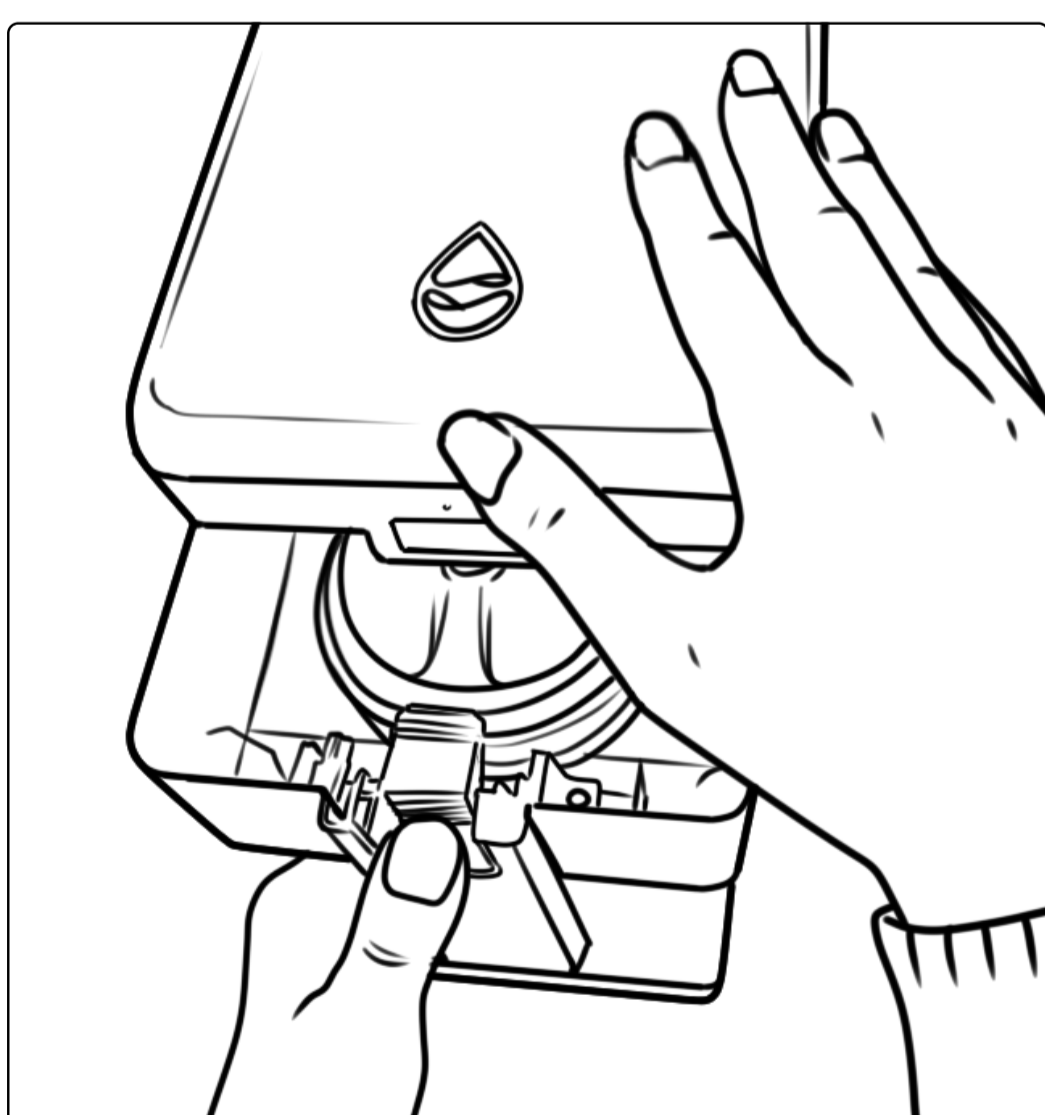

Recommended to place open hand on top of your Filter when removing or inserting the canister.

Note: If insertion is difficult, the canister is likely misaligned or the lid is not fully locked into place. Remove the canister and evaluate before attempting to insert again.

Note: The Pod can typically be used for 5 loads or about a week under normal household conditions before it needs to be replaced with a new Pod.

IMPORTANT: Remember to make sure the canister lid is in place. If the canister lid is not properly in place, it is possible for washing machine drain water to escape from your Filter. Once your Filter is powered on (later in installation) the Pod light will blink yellow if the canister lid is not detected.

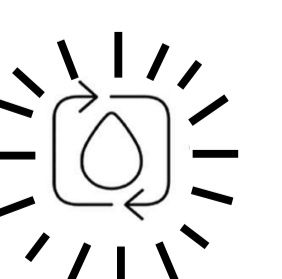

Installing Your Filter

Step 7: Insert the CLEANR VORTX

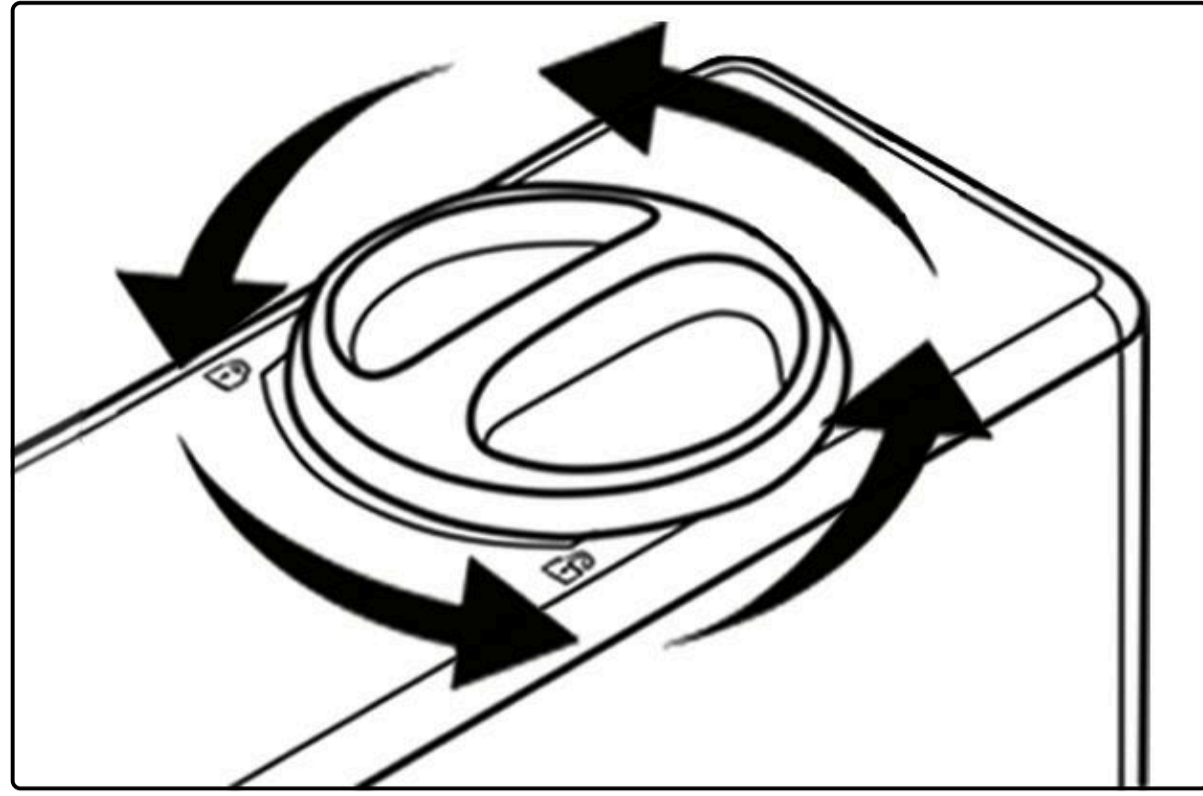

Remove the top lid of your Filter by twisting the top lid counter-clockwise, following the indicator from locked to unlocked. Then, lift the top lid to reveal the inside of the Filter chamber.

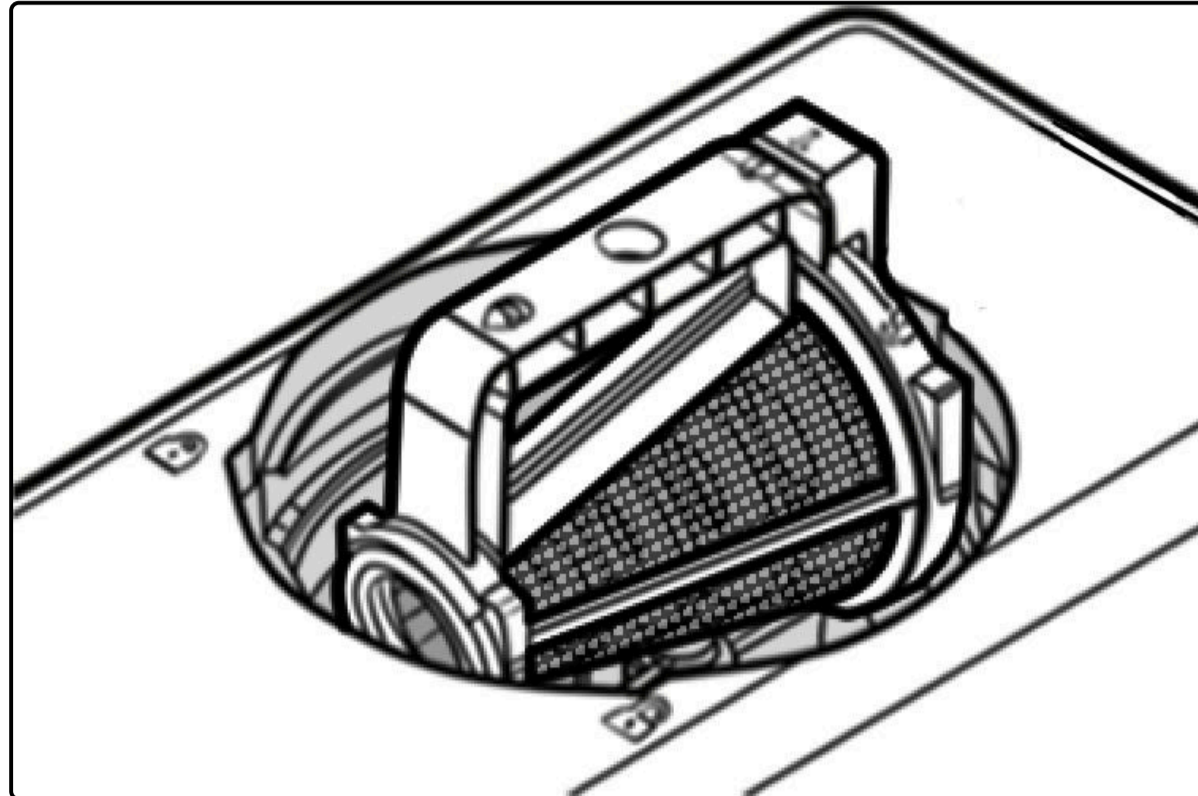

Insert the VORTX assembly into the Filter chamber with the sleeve handle pointing up and push down. The wide end of the VORTX should face the back of the Filter.

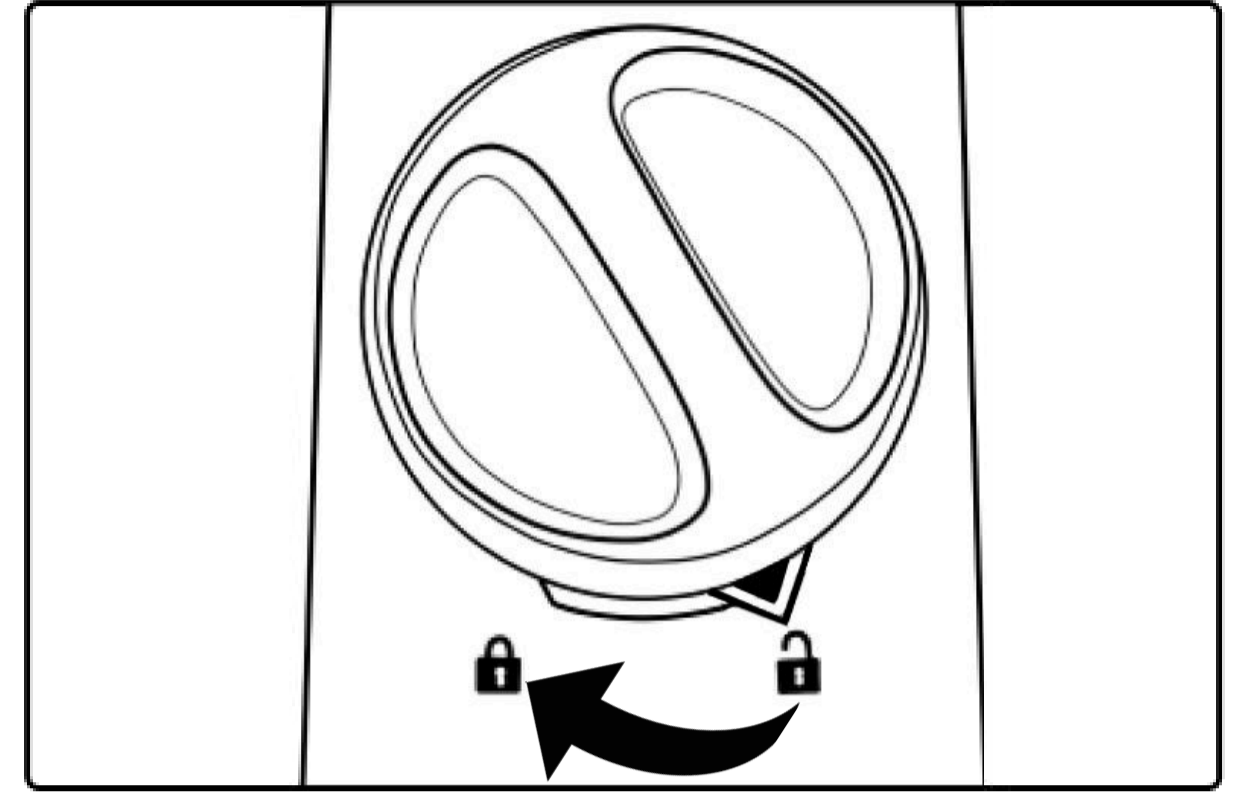

Fit your Filter's top lid back into place on the top of your Filter, aligning the small pointed alignment indicator on the top lid with the UNLOCK symbol on the top of your Filter. Then turn the top lid clockwise, following the indicator from unlocked to locked.

Note: The VORTX can typically be used for about a month under normal household conditions before they need to be cleaned. Households with pets and / or with a noticeable amount of pet hair on laundered items will likely need to clean the VORTX more frequently.

IMPORTANT: Remember to make sure the top lid is in place. If the top lid is not properly in place, it is possible for washing machine drain water to escape from your Filter. Once your Filter is powered on (later in installation) the VORTX light will blink yellow if the top lid is not detected.



Step 8: Optional Brush Hook Storage

Remove the adhesive backing from the cleaning brush hook.

Place hook on the side of your Filter, on your washing machine, or on a wall.

Note: clean surface before applying hook.

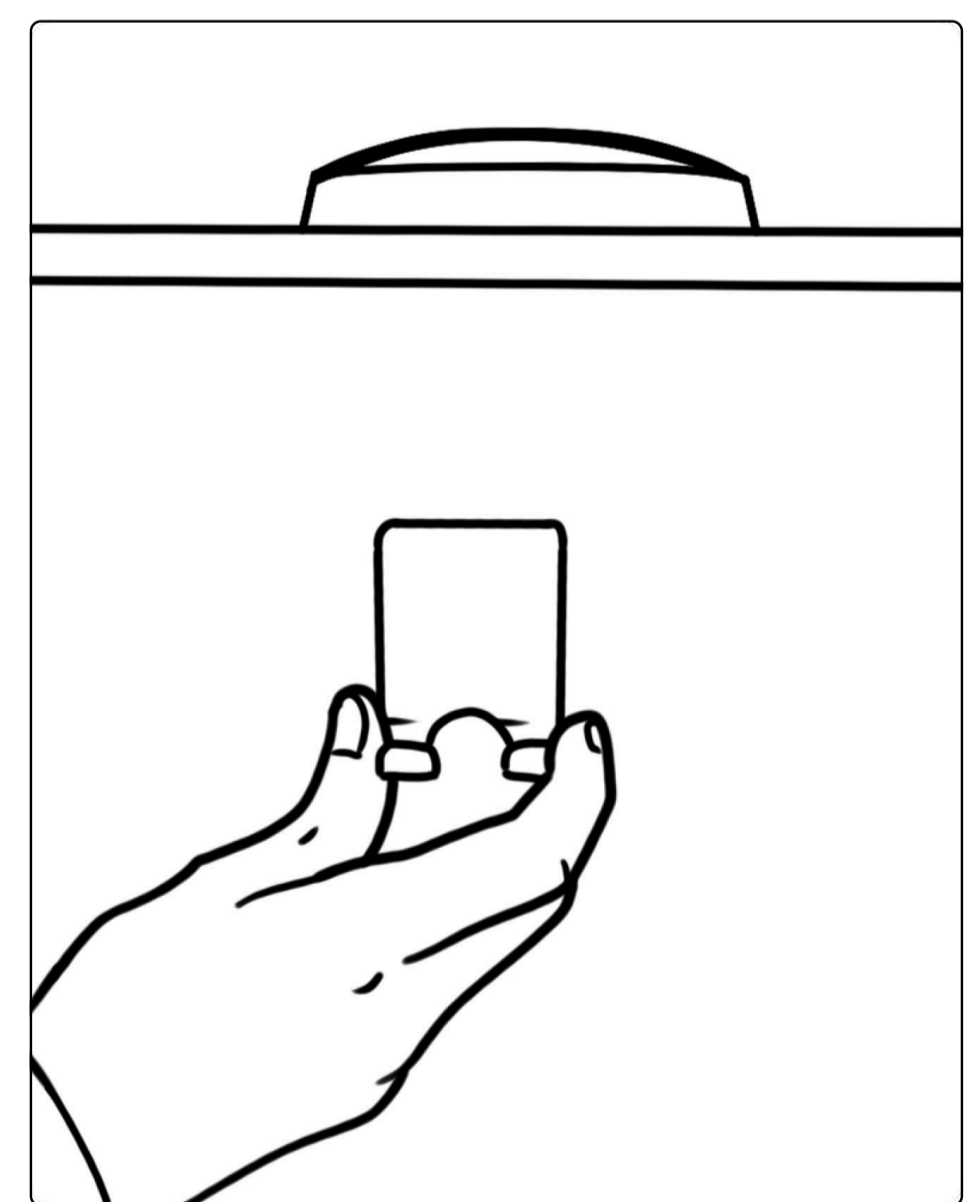

Hang your cleaning brush on the hook.

Note: Hook is not to be used for other purposes.

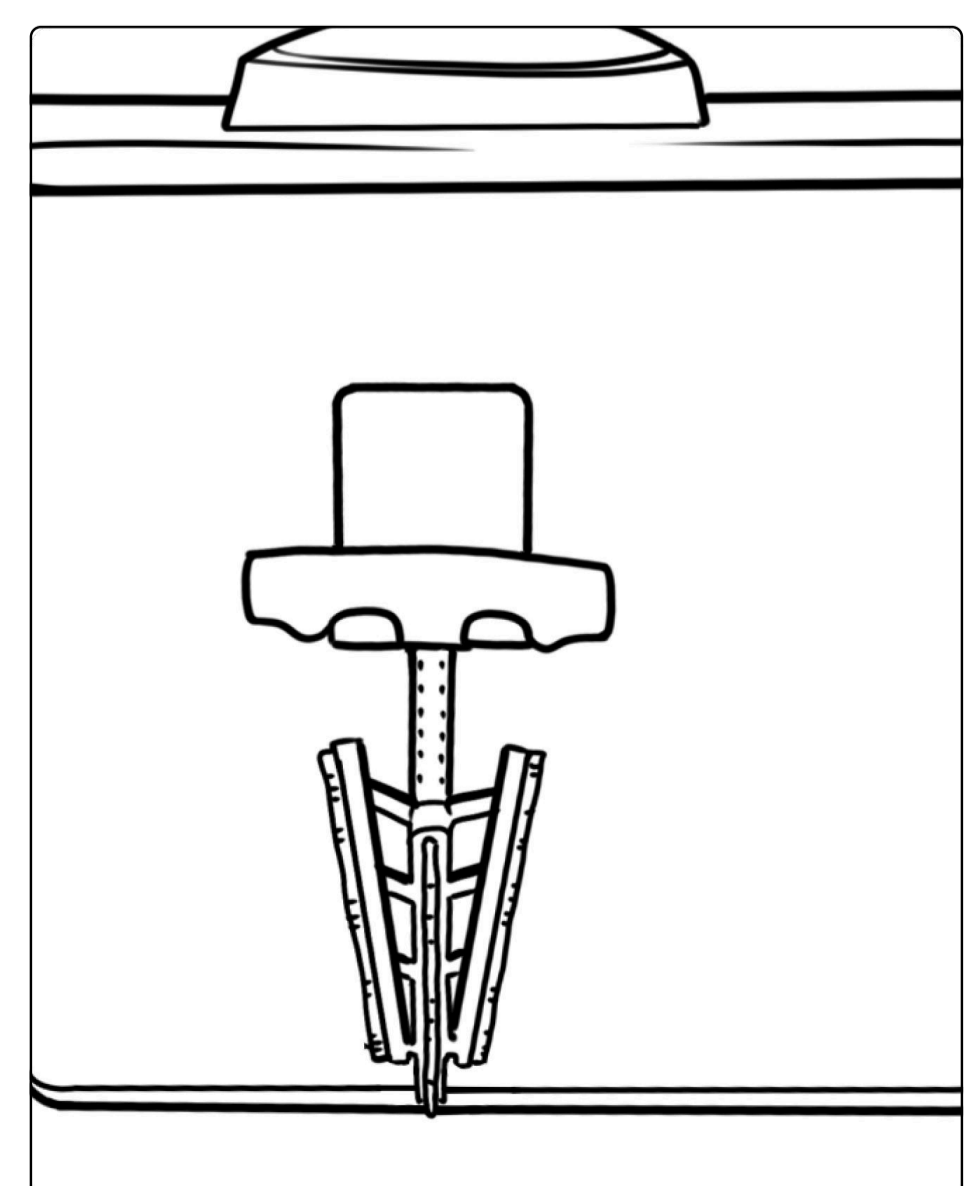

Installing Your Filter

Step 9: Connect the Power Cord and Turn On Filter

To connect your Filter to power and turn on, you will need the following components

- a. Filter
- b. Power Cord

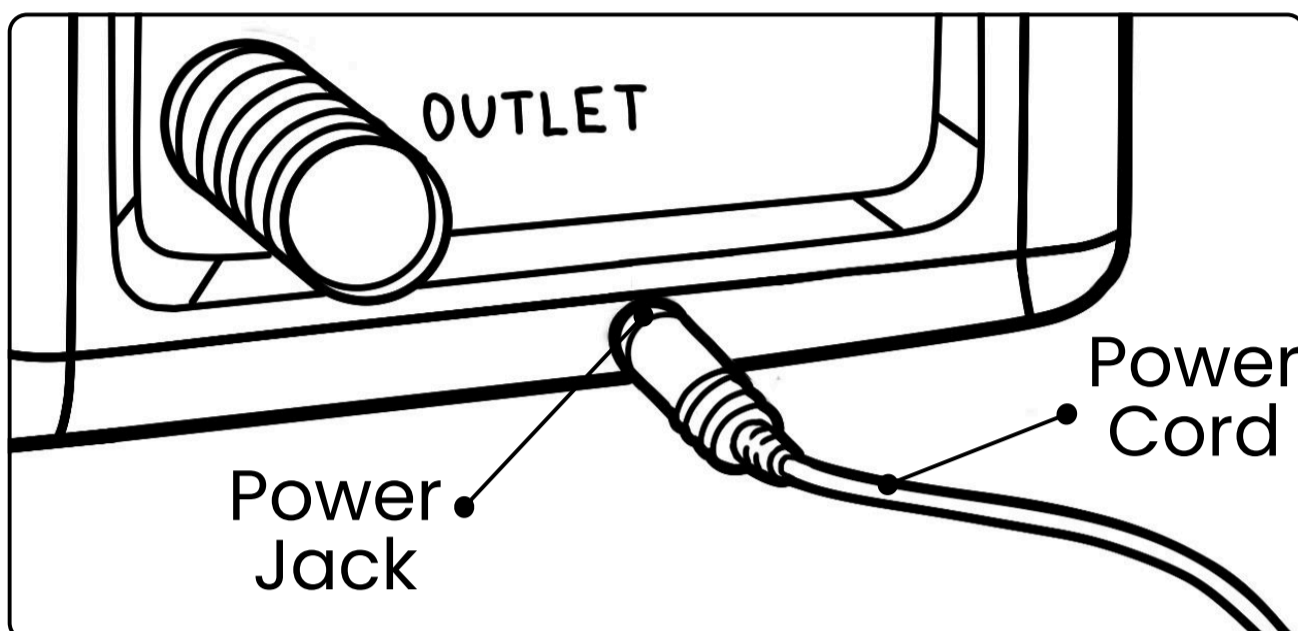
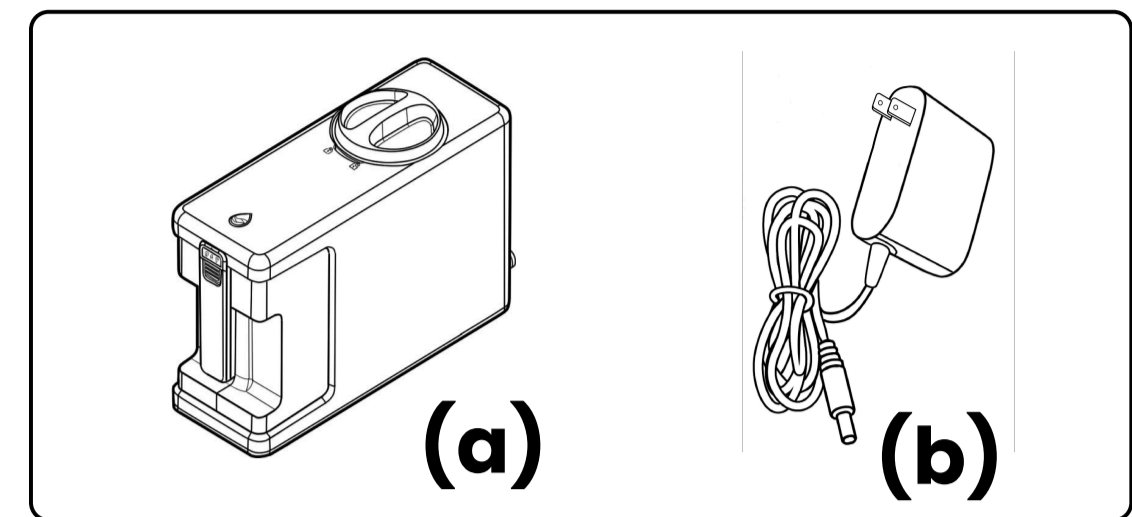

Plug the small end of the power cord into the power jack on the back of your Filter.

Note: your Filter should have a hose on the outlet connection, not shown in image above.

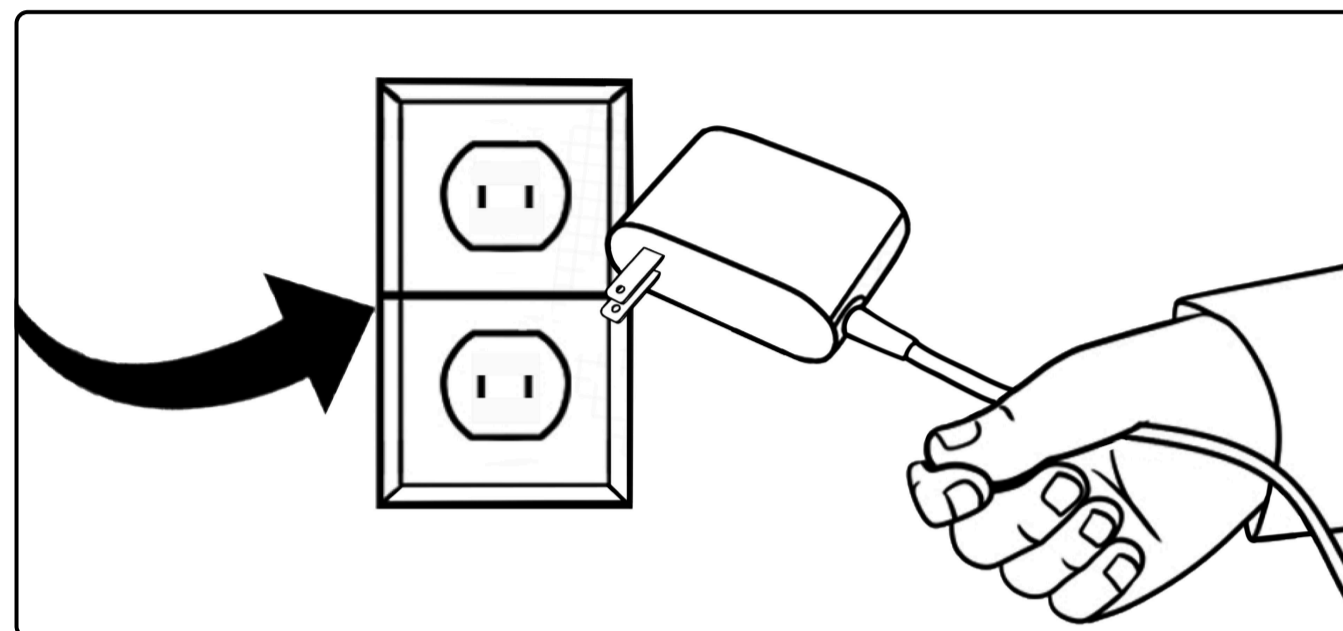

Insert the power cord plug into an electrical outlet.

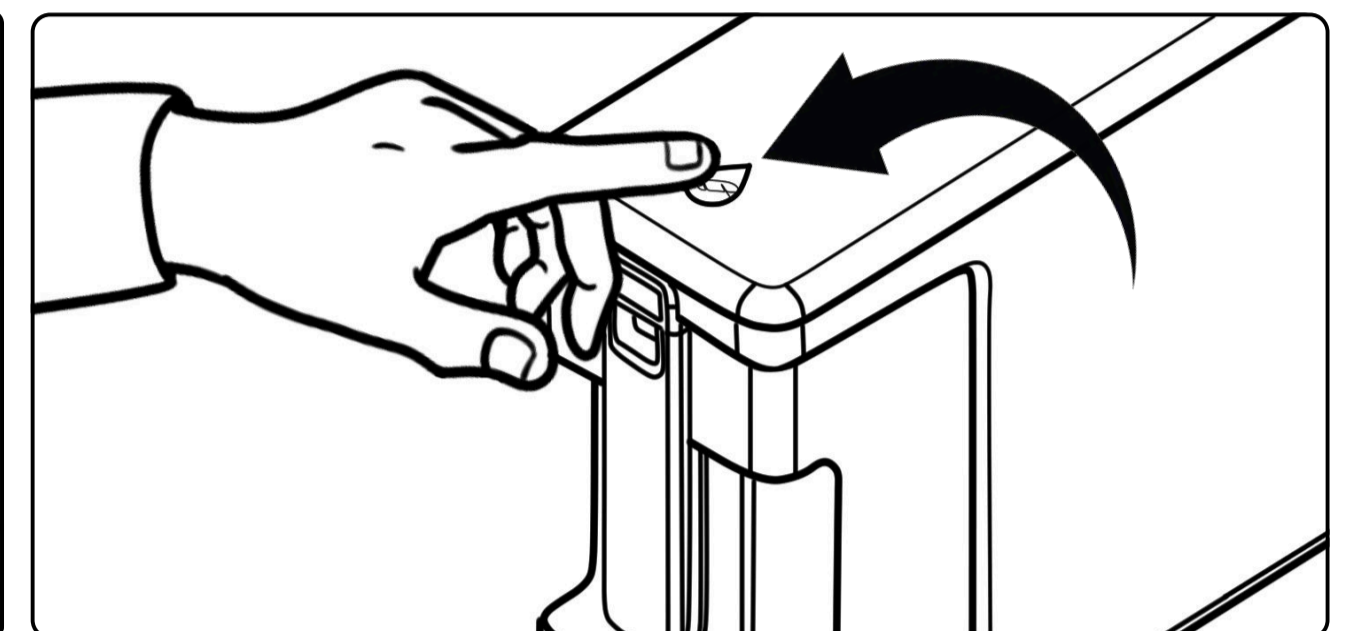

Press button to turn your Filter ON.

After pressing the On / Off button, your Filter starts up. Your Filter status Icons will illuminate in succession as noted below:

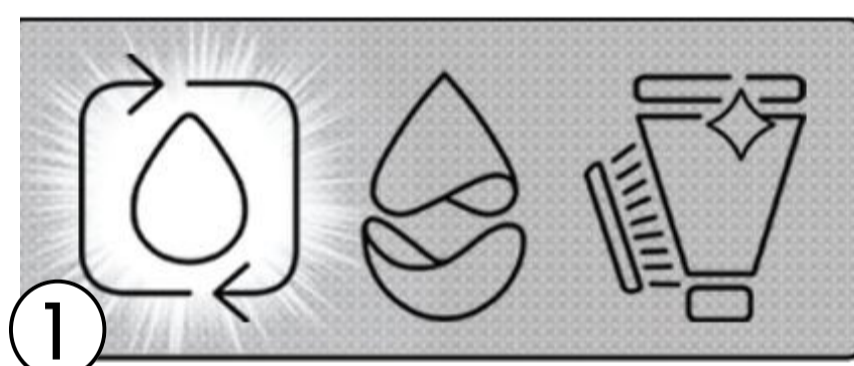
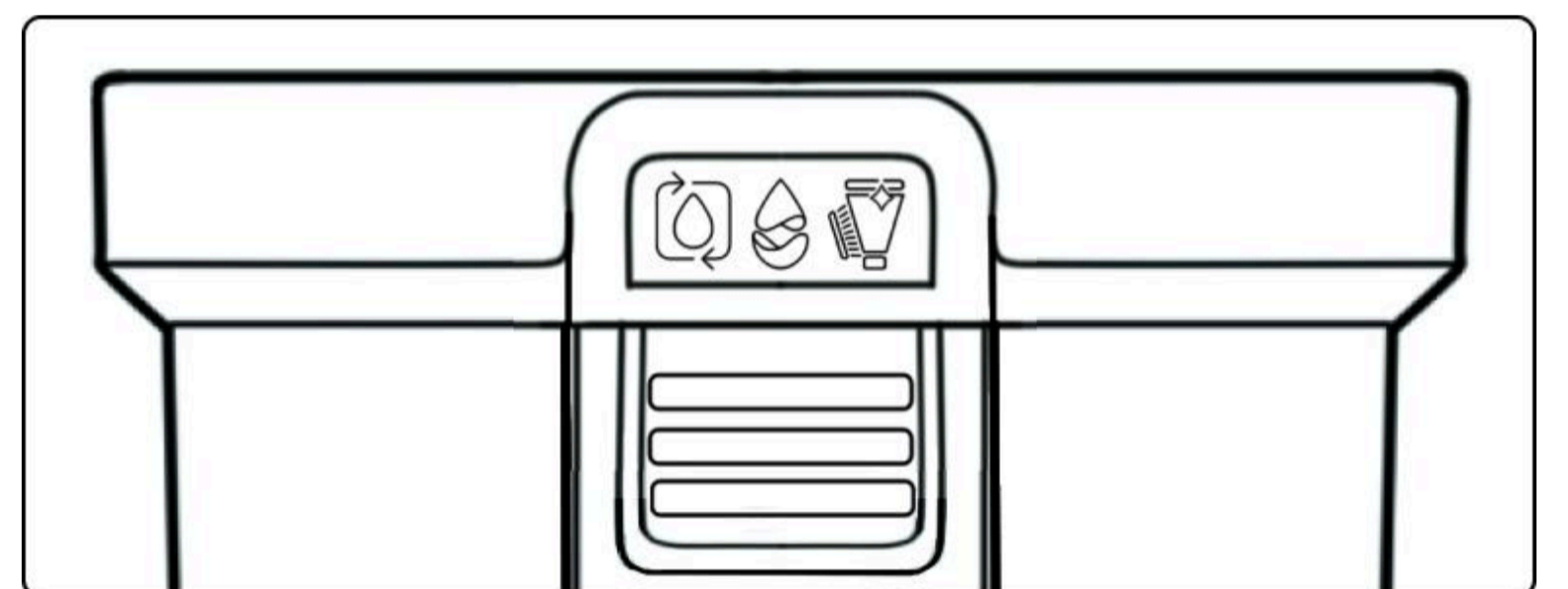

1 Pod light turns white.



2 Water drop turns white.



3 VORTX turns white.



4 Water drop turns blue.

IMPORTANT: Your Filter should only be used with the provided power adapter

Ready to Filter

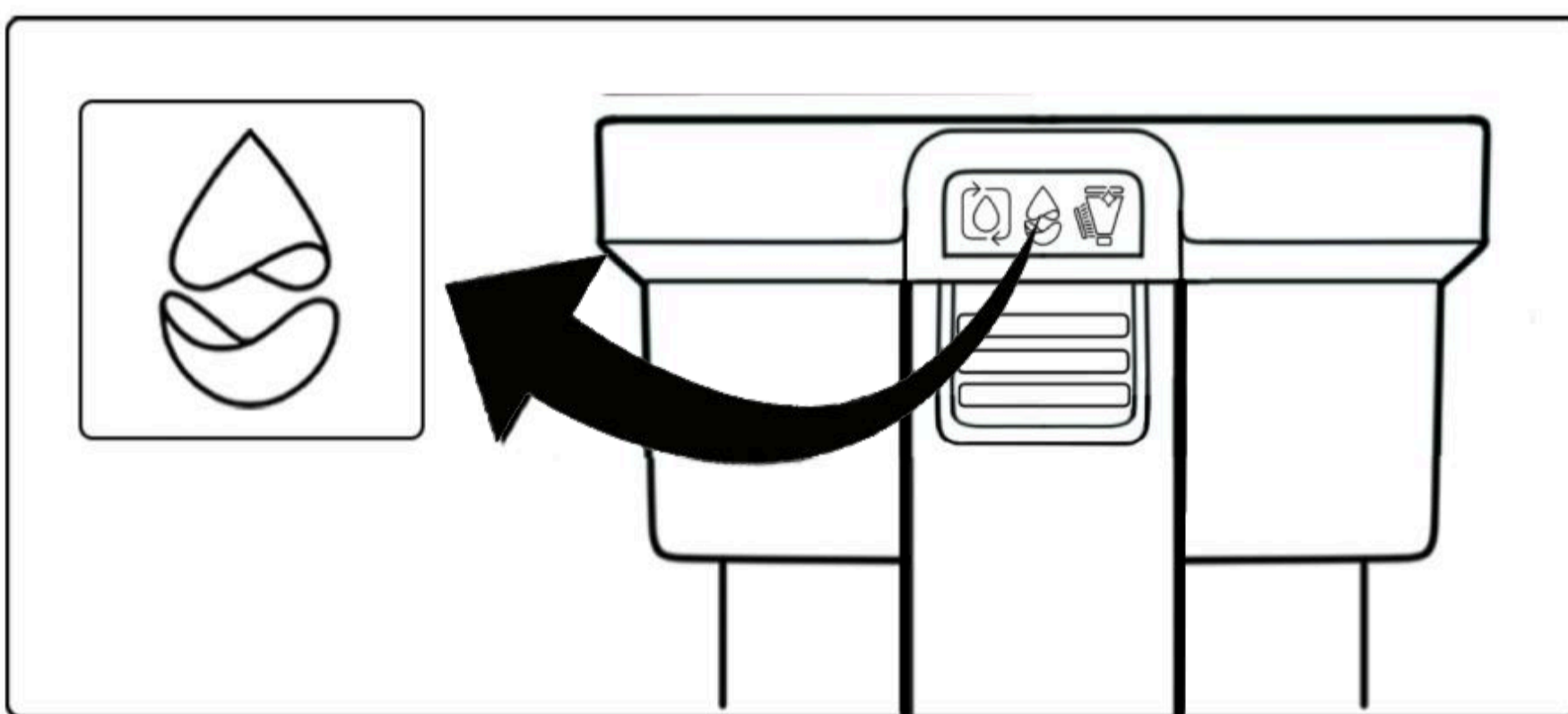

When the water drop status Icon is blue, your Filter is ready to Filter.

IMPORTANT: If the water drop status Icon is not blue after performing steps 1 - 9 above, then your Filter is not ready to Filter. If any of the status icon lights are yellow, check your Filter status indications section of this User Guide for information about how to resolve. If any of the status icon lights are red, check the Troubleshooting section (page 18) of this User Guide for information about how to resolve.

Step 10: Installation Check

- 1. Washing machine hose connected to your filter inlet (grey)
- 2. CLEANR provided hose connected to your filter outlet (white)
- 3. Hose clamps tight
- 4. CLEANR Pod Installed
- 5. CLEANR VORTX Installed
- 6. CLEANR Filter turned on
- 7. Middle LED on your Filter illuminated blue

Installing Your Filter

Step 11: Connect to the CLEANR App

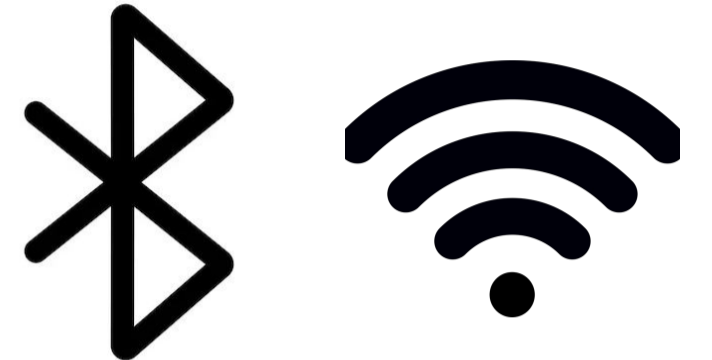

Connect to Wi-Fi and Perform Smart Home Setup

Your CLEANR Filter is Wi-Fi enabled and can be paired with the CLEANR App on your Apple or Android smart phone. With your Filter paired to the CLEANR App, users can view status notifications, receive important maintenance notifications, and view the amount of microplastics captured from your Filter's usage over time.

- Ensure your Bluetooth is enabled and discoverable on your smart phone with the proper permissions granted to the CLEANR App. Next, ensure you have a good home Wi-Fi signal near your Filter. Your CLEANR Filter requires a good Wi-Fi signal to connect to Wi-Fi.
- Download and install the CLEANR App onto your smart phone called "CLEANR Filter" on the Apple Store and "CLEANR" on the Google Play Store.
- Follow the on-screen instructions in your CLEANR App to pair and register your CLEANR Filter and to connect it to your Wi-Fi network.

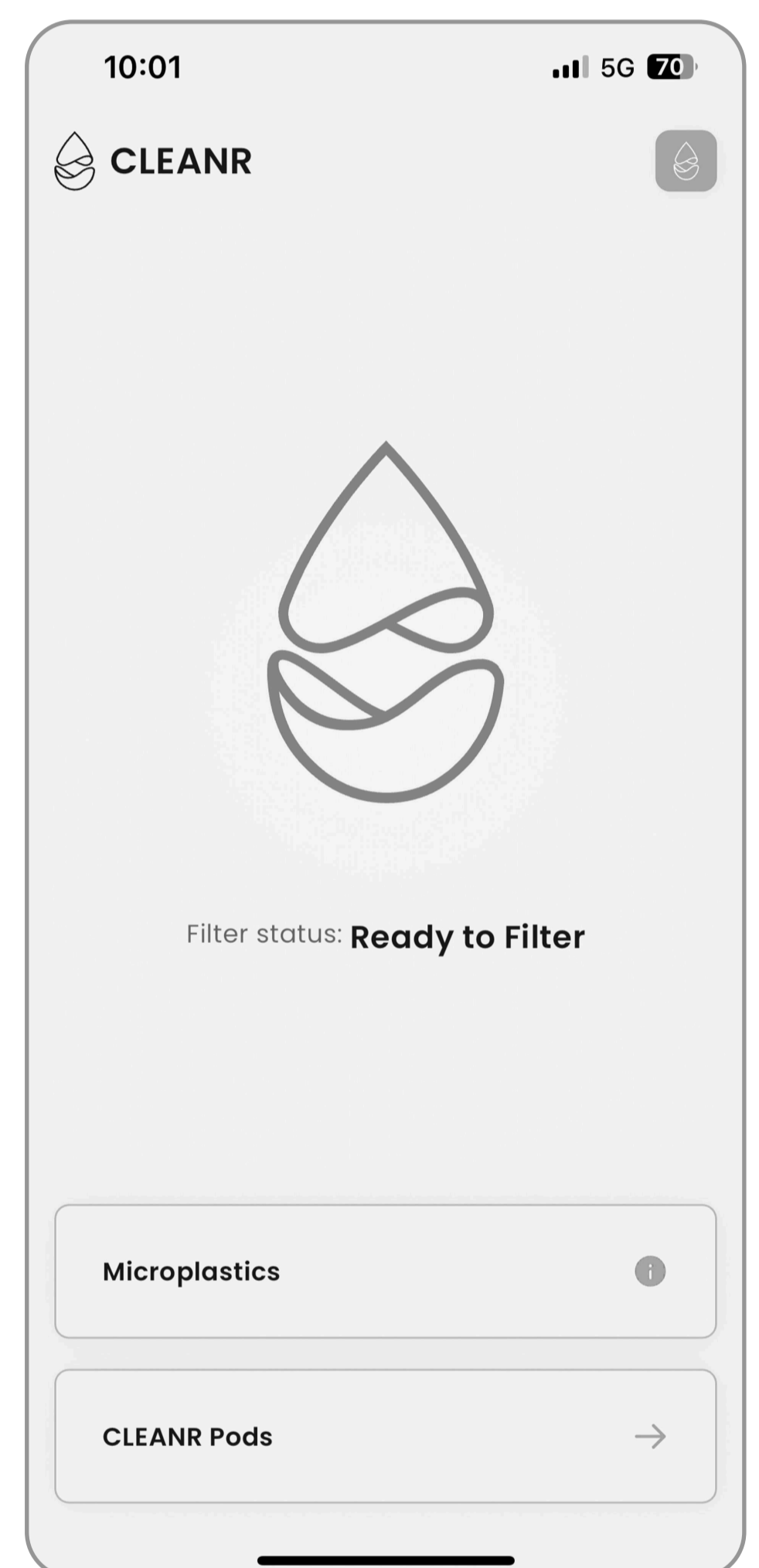

Bluetooth Connection Lights:

Once the device has been selected on the CLEANR App, the status indication lights will begin to breathe to confirm connection to smartphone via Bluetooth. Follow the app step to connect to Wi-Fi.

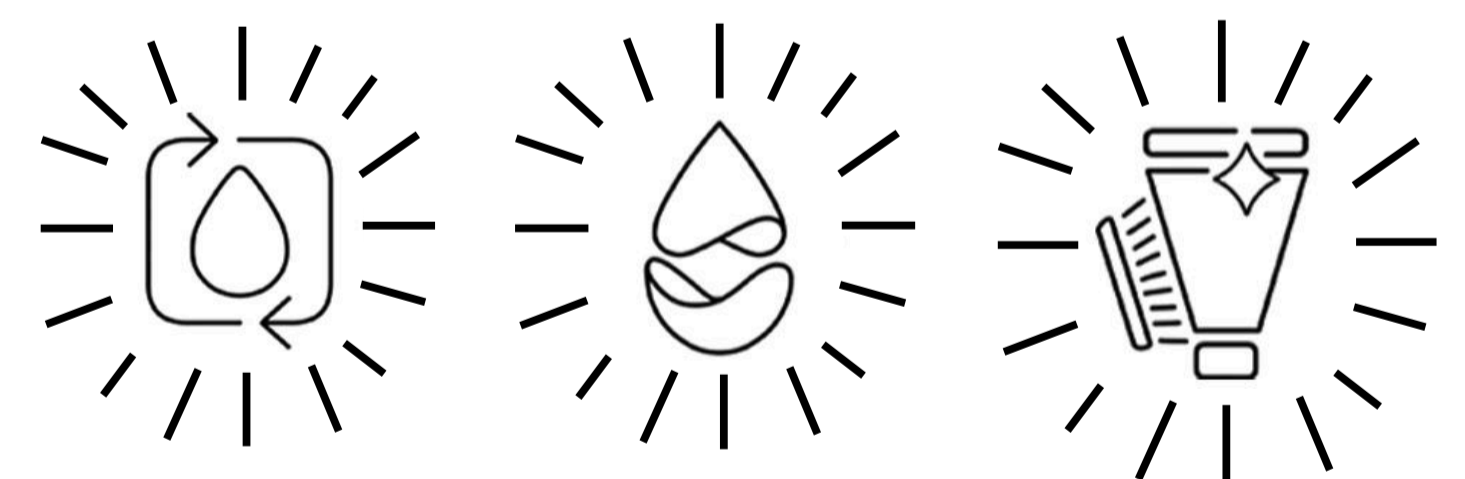

Connection Confirmation

Once the connection process is complete and your device is connected to Wi-Fi, the notification light will turn back to blue:



Water Drop turns blue.

Note: When your Filter is powered off, then powered back on again, your Filter will automatically re-connect to the Wi-Fi network.

Note: This Wi-Fi and CLEANR App setup can be performed at during the installation or any time during Filter use. For App connection, your Filter must be powered on. It is recommended to connect the App during installation.

Installing Your Filter

Resetting Your Wi-Fi Connection:

To reset your Filter's Wi-Fi connection, follow the steps in the CLEANR App.

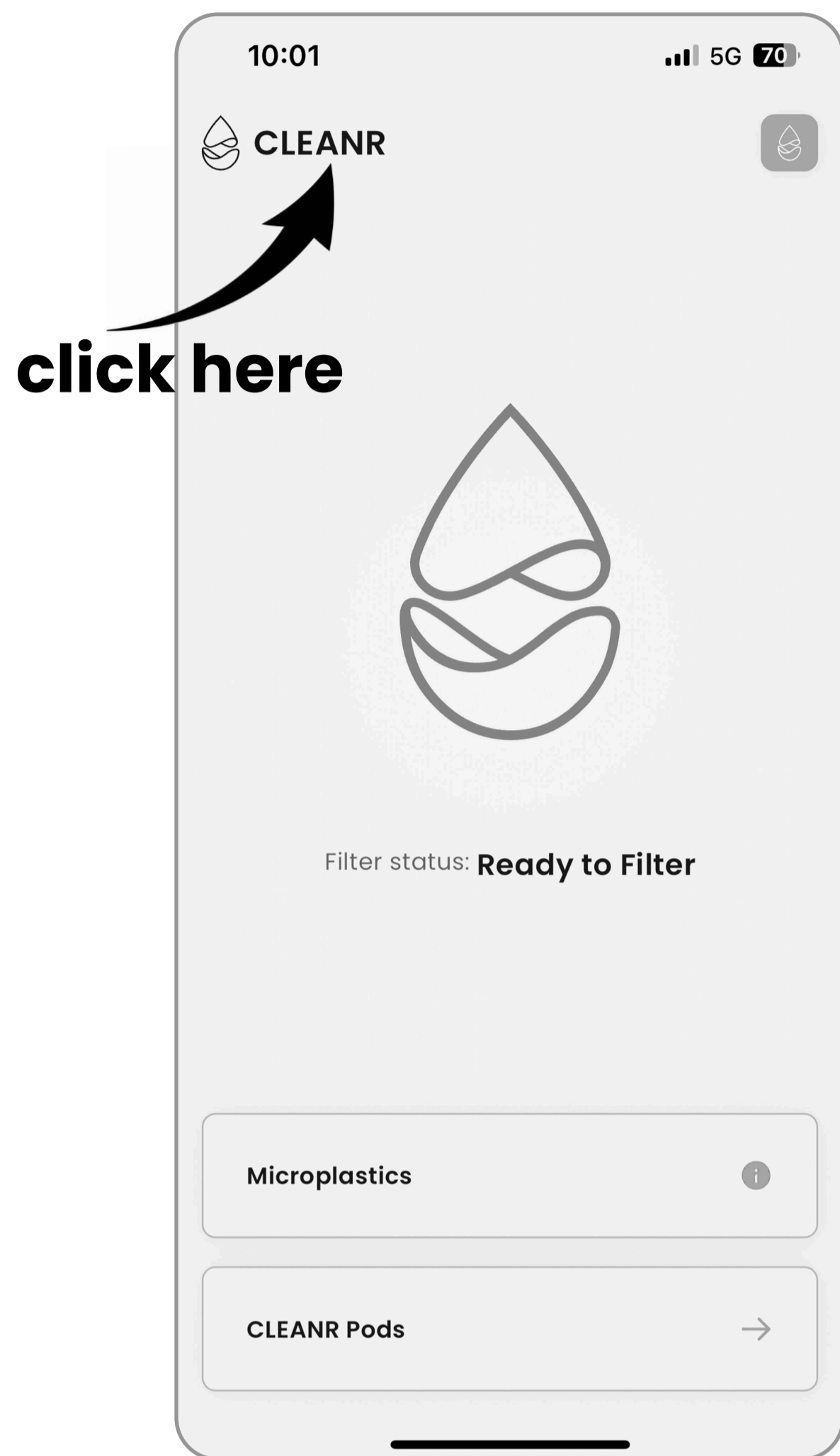

a. From the app status screen, click on the CLEANR logo in the top left.

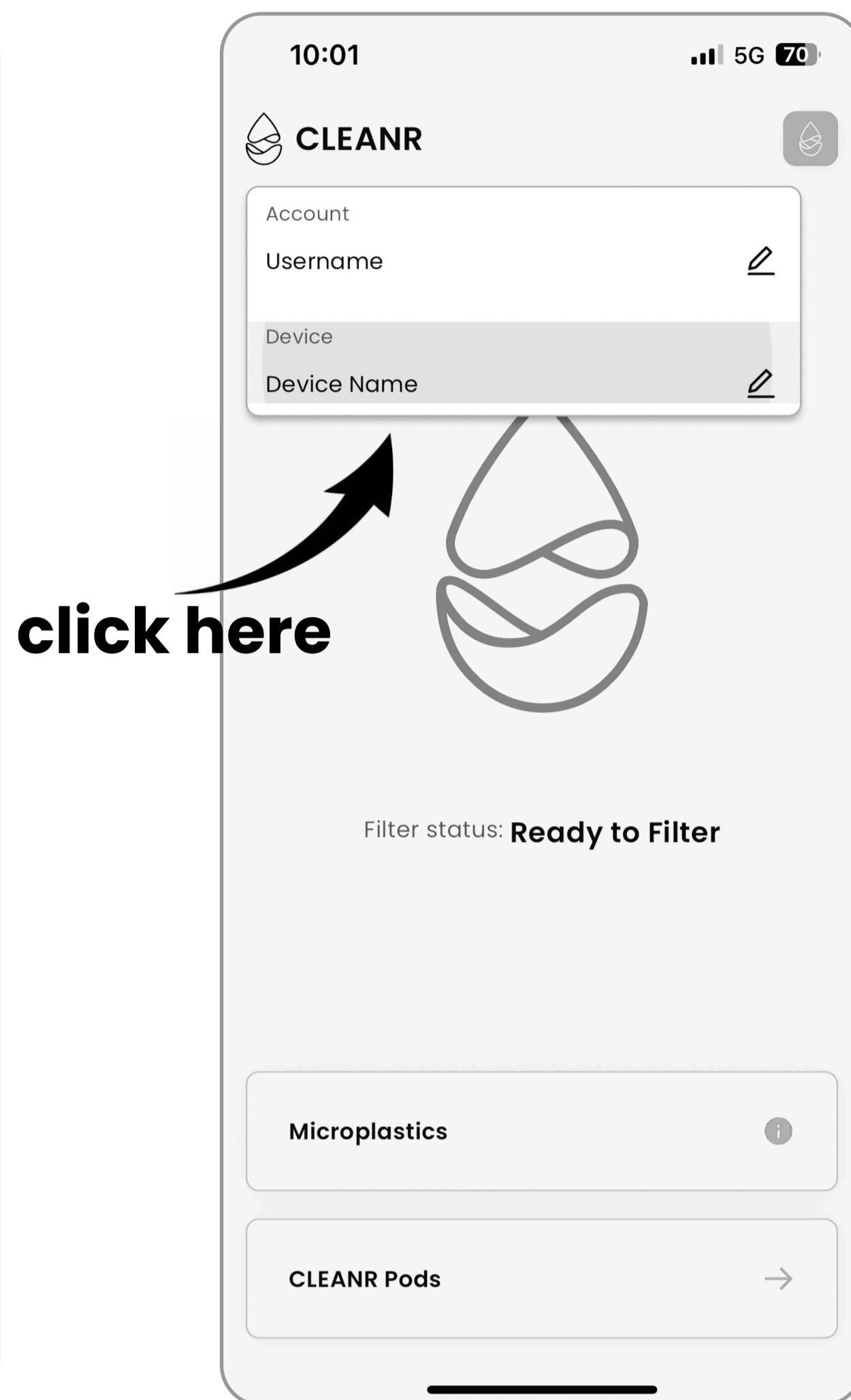

b. Click to edit your device.

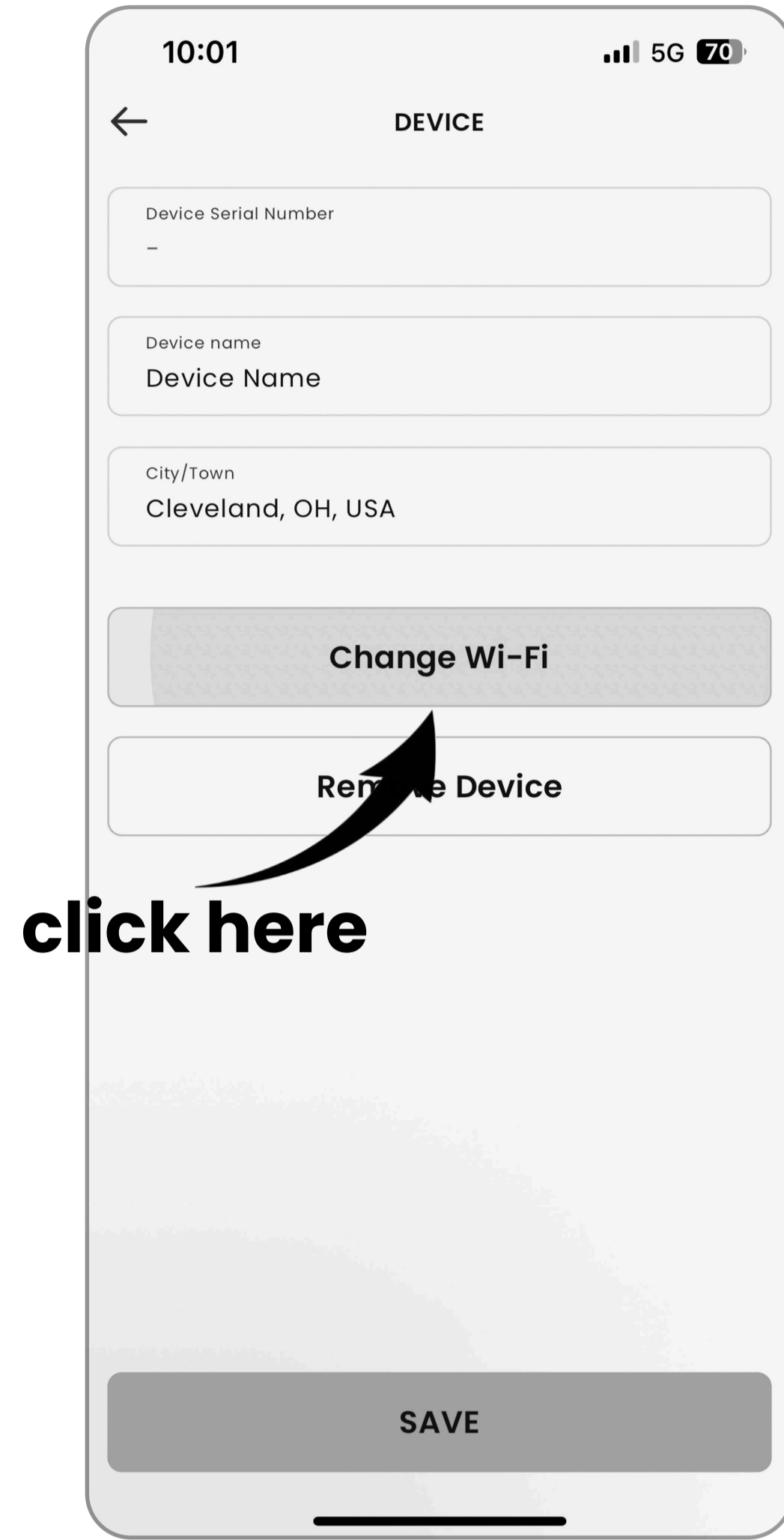

c. Click the "Change Wi-Fi" button. Follow the instructions on your app.

Bluetooth will re-connect to your device. Then, you can select an available Wi-Fi network.

This may need to occur if: you loose Wi-Fi, you change your Wi-Fi settings, or you want to switch your device's network.

Step 12: Run a Test Cycle

Run a washing machine rinse or quick cycle with your Filter connected to ensure your Filter is properly installed and is not leaking.

IMPORTANT: Check for leaks during and after the cycle.

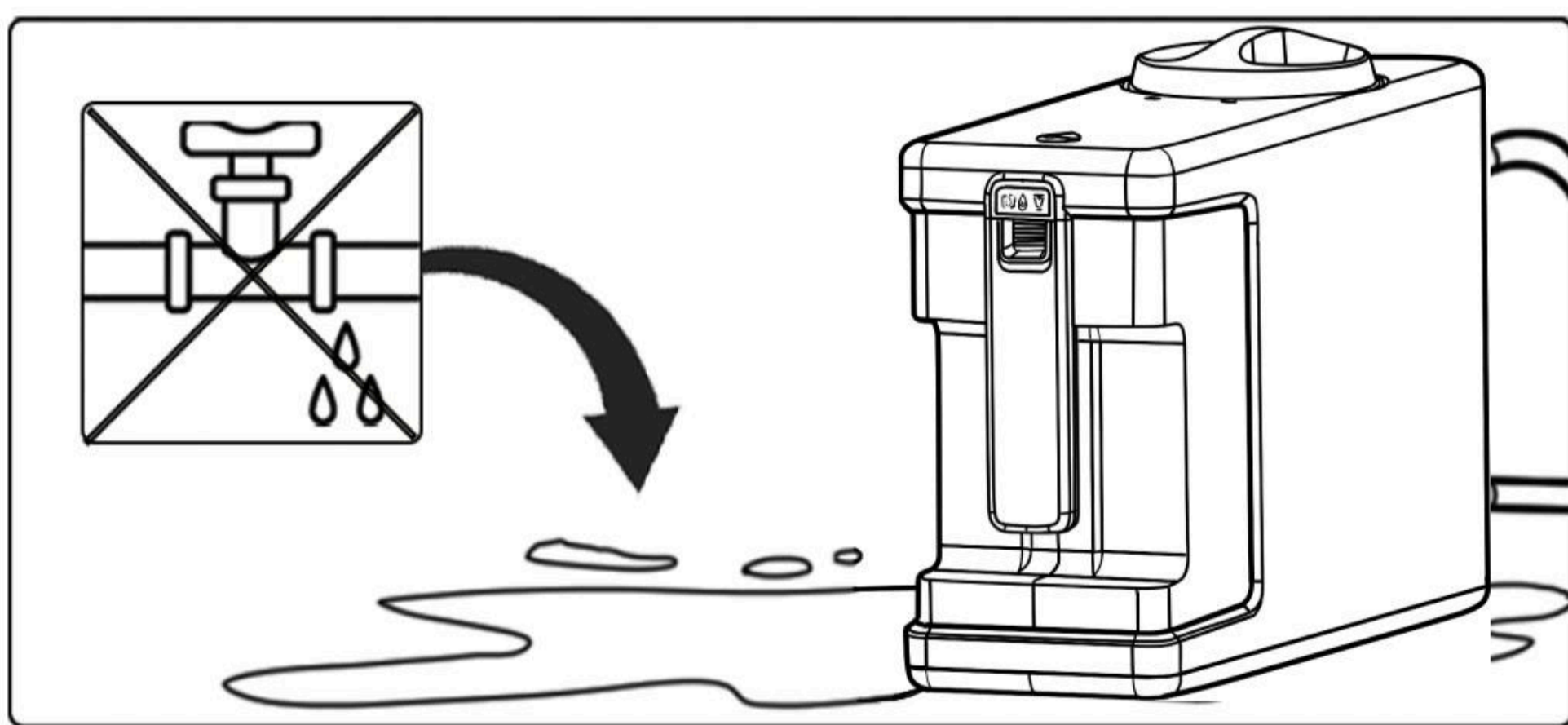

IF LEAKING, pause the washing machine and turn off your Filter. Then perform the following:

- Check that the hose connections and hose clamps are tight.
- Check that there are no kinks in or obstructions to the hoses.
- Check the canister lid and top lid to ensure they are fully tightened and locked into place. Both lids must be pushed all the way in and turned to the locked positions.
- Check that the canister is fully locked into place.

If there are no leaks from your Filter or the hoses when running the rinse cycle, then proceed to the Using Your Filter section of this User Guide.

Using Your Filter

Running your Filter

The following must be in place to successfully run the CLEANR Filter with your washing machine:

- Hose securely connecting the washing machine your CLEANR Filter Inlet with hose clamp
- Hose securely connecting your Filter outlet to the laundry sewer with hose clamp
- Pod installed inside Filter canister
- Canister lid fully locked into place
- Filter canister fully locked into place
- VORTX filter in place inside the Filter chamber
- Filter top lid locked into place
- Filter powered ON and middle status icon is illuminated blue

Your CLEANR Filter will filter the water which drains from the washing machine each time the washing machine is run.

IMPORTANT: Before running the washing machine, ensure that your Filter is powered ON and the Status Icon on the front of your Filter is illuminated blue. Operating the washing machine while connected to your Filter which is not turned ON or does not have the Status Icon illuminated blue may result in error indications from the washing machine and / or leaks from the washing machine, your Filter, or the hoses.

Filter Status Indications

From time to time, your Filter will require cleaning (i.e. changing the Pod or cleaning the CLEANR VORTX). Your Filter's Status Icons indicate when each type of maintenance is required.

See the Maintenance section of this User Guide for instructions on how to perform Filter maintenance as needed.

- When the CLEANR light water drop icon is blue, your Filter is in normal/operational status.
- When a Filter light status icon is yellow indicates maintenance is required for either the Pod or the VORTX.
- A Filter status icon light that is blinking yellow or red indicates a component of your Filter has been removed or is not correctly in place.

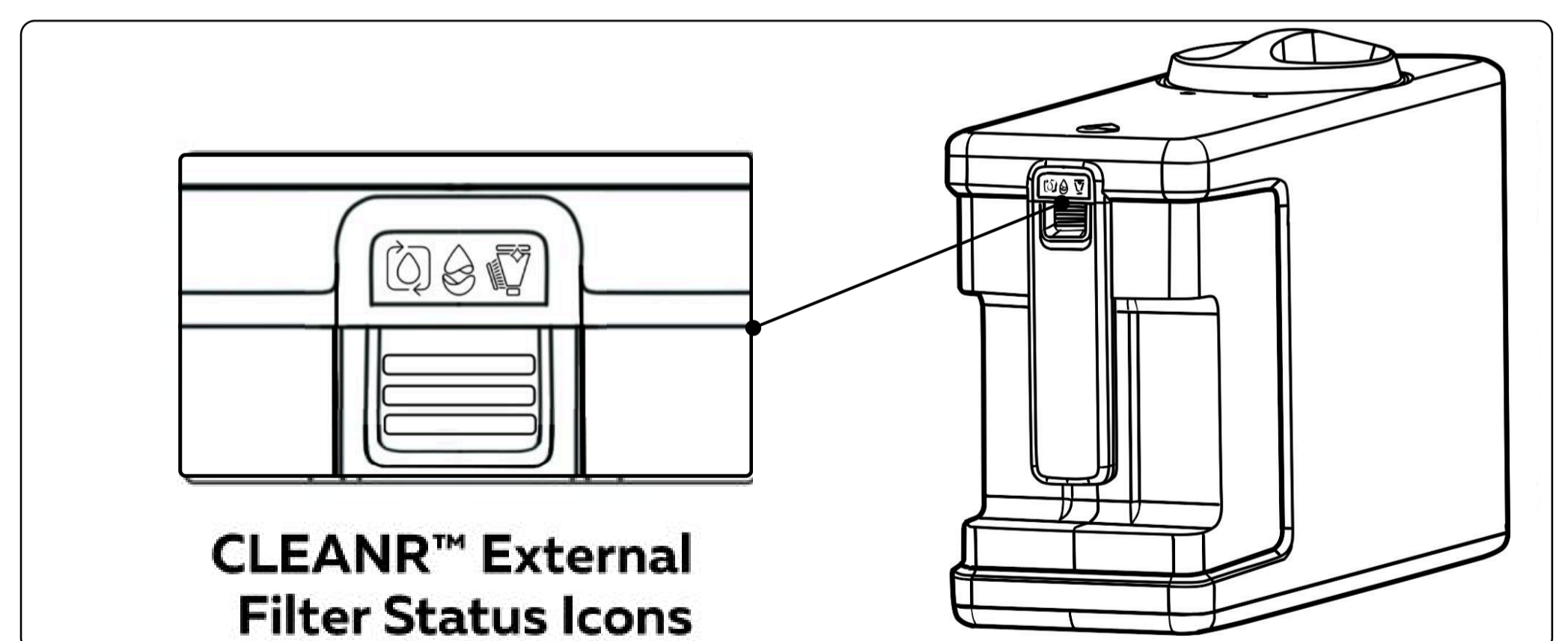

See next page for explanation of your Filter's Status indications.

IMPORTANT: Filter maintenance (i.e., changing the Pod or cleaning the VORTX Filter) should ONLY be performed in between washing machine cycles, with your CLEANR Filter powered on, and the washing machine powered off, .

Using Your Filter

Filter Status Indications

Filter Startup

The Status lights each turn SOLID WHITE from left to right in succession when your Filter is turned on and runs its startup routine



Filter Connection

The Status lights BREATHE WHITE as your Filter connects to your smartphone

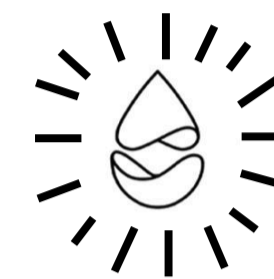
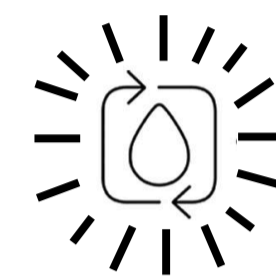

The Pod Status Light appears as...

SOLID YELLOW



- When a used Pod needs to be replaced with a new Pod

Note: Replace the Pod only after the current washing machine cycle is complete.

BLINKING YELLOW

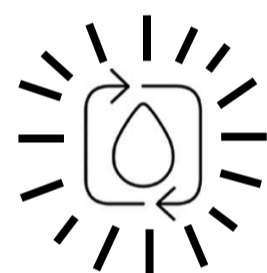

- When either the canister or canister lid has been removed (for example, when they are removed in order to change the Pod)
- Or when either the canister or the canister lid is not completely locked into place.

The Water Drop Status Light appears as...

SOLID BLUE



- When the unit is ready to filter.

The VORTX Status Light appears as...

SOLID YELLOW



- When the VORTX needs to be cleaned

Note: Clean the VORTX only after the current washing machine cycle is complete.

BLINKING YELLOW



- When either the VORTX or the top lid has been removed (for example, when they are removed to clean the VORTX)
- Or when either the VORTX or the top lid is not completely locked into place.

IMPORTANT: Never open or remove any components of your Filter while the washing machine is running. Doing so can result in washing machine drain water escaping from your Filter.

BLINKING RED status icons indicate when a component is missing or out of place while your Filter should be operating. The user should pause the washing cycle then install missing components. The status icons will blink red, and the user will also be notified on the CLEANR Smart App.



See the Troubleshooting section of this User Guide for an explanation of the error conditions.

Maintenance of Your Filter

Changing the CLEANR Pod

Under typical household conditions, the CLEANR Pod will need to be replaced about once per week or every 5 loads of laundry. With heavy cotton contents the frequency may increase while lighter loads will cause the frequency to decrease. Households with pets and / or with a noticeable amount of pet hair in or on laundered items will often need to change the Pod more frequently.



Change the CLEANR Pod when the Pod status icon illuminates with a solid yellow light.

1. Scan this QR code with your smart phone to see a video with an overview of changing the CLEANR Pod.



IMPORTANT: Changing the CLEANR Pod should **ONLY** be performed in between washing machine cycles. It is suggested to wait 30–45 minutes after the wash cycle to access the Pod as your Filter components may be hot.

IMPORTANT: When changing the CLEANR Pod, it is recommended to wear gloves to avoid bacteria contamination from your filtered material.

2. Removal of used Pod

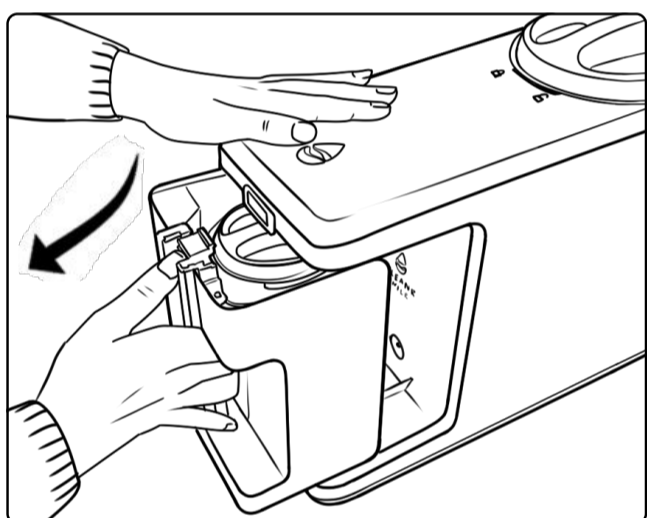

2a. Press down on the canister button. Then pull in the direction of the arrow (as shown in the figure) to remove the canister.

Recommended to place open hand on top of your Filter when removing

Note that when you remove the canister, the Pod Status light will blink yellow.

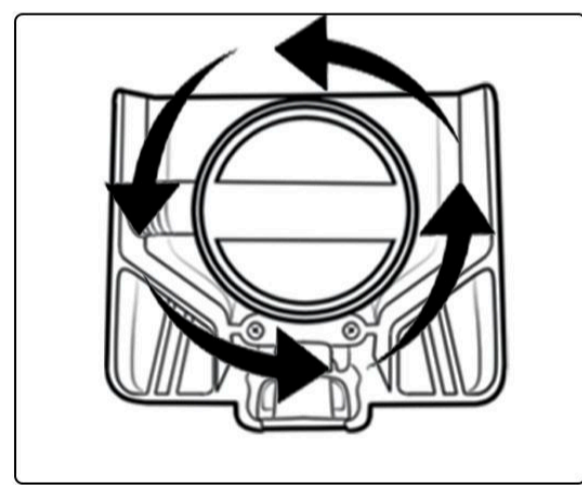

2b. Twist off the canister lid, turning counterclockwise to open and then lift the lid. You now will be able to access the Pod.

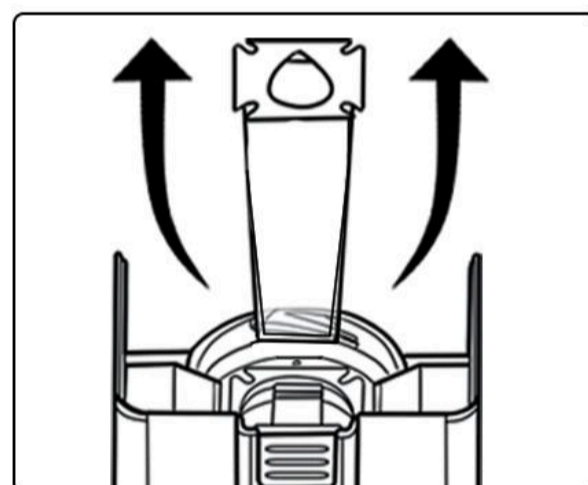
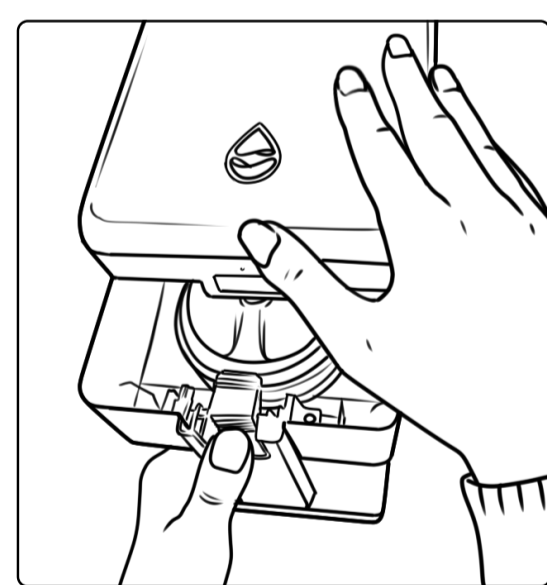

2c. Remove the used CLEANR Pod from inside the canister.

Generally, the used Pod will look like there is a thin, dirty film coating the inside of it. These are captured microplastics.

If the Pod has residual water in it, see the box below.

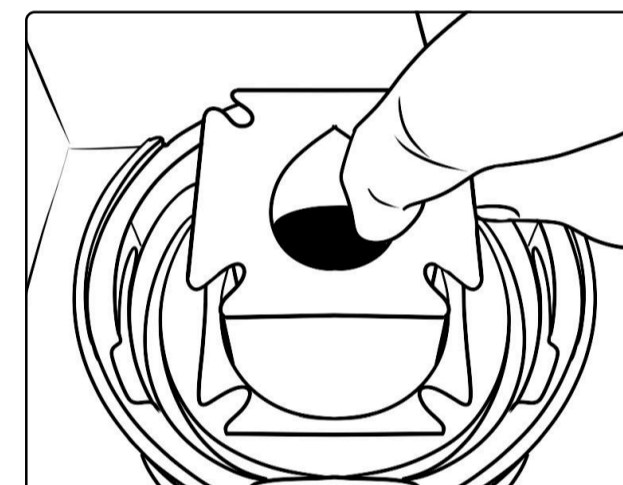

TIP: You may find it helpful to grasp the Pod just inside the water drop shaped opening to lift it from its seat on the Canister.

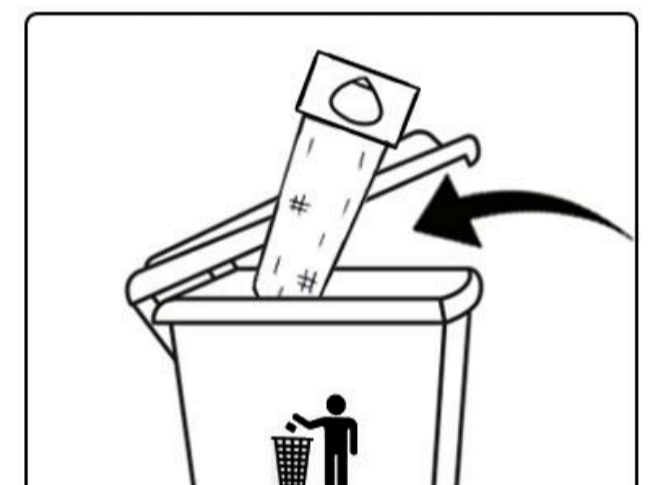

2d. Dispose of the used Pod in the trash receptacle.

Do not rinse the captured material from the Pod down the sink.

You may also notice other conditions of the Pod from time to time:



CLEANR™ Pod has residual water in it. You can dispose the Pod with the water in it in the trash bin or leave the Pod in the canister for around 60 min to drain. Do not empty the residual water into the sewer or sink.



CLEANR™ Pod is full of debris and looks "stuffed". This may occur from time to time, particularly when you wash certain garments or items made of fabric types that "shed" heavy amounts of microfibers, pet hair, dirt, sand, etc.



CLEANR™ Pod appears to be clean. This typically occurs when the laundry items washed are mostly white and / or very light in color, and the microfibers captured in the Pod are very similar to the color of the unused Pod.

IMPORTANT: Do not rinse the captured material from the Pod down the sink.

Maintenance of Your Filter

Changing the CLEANR Pod

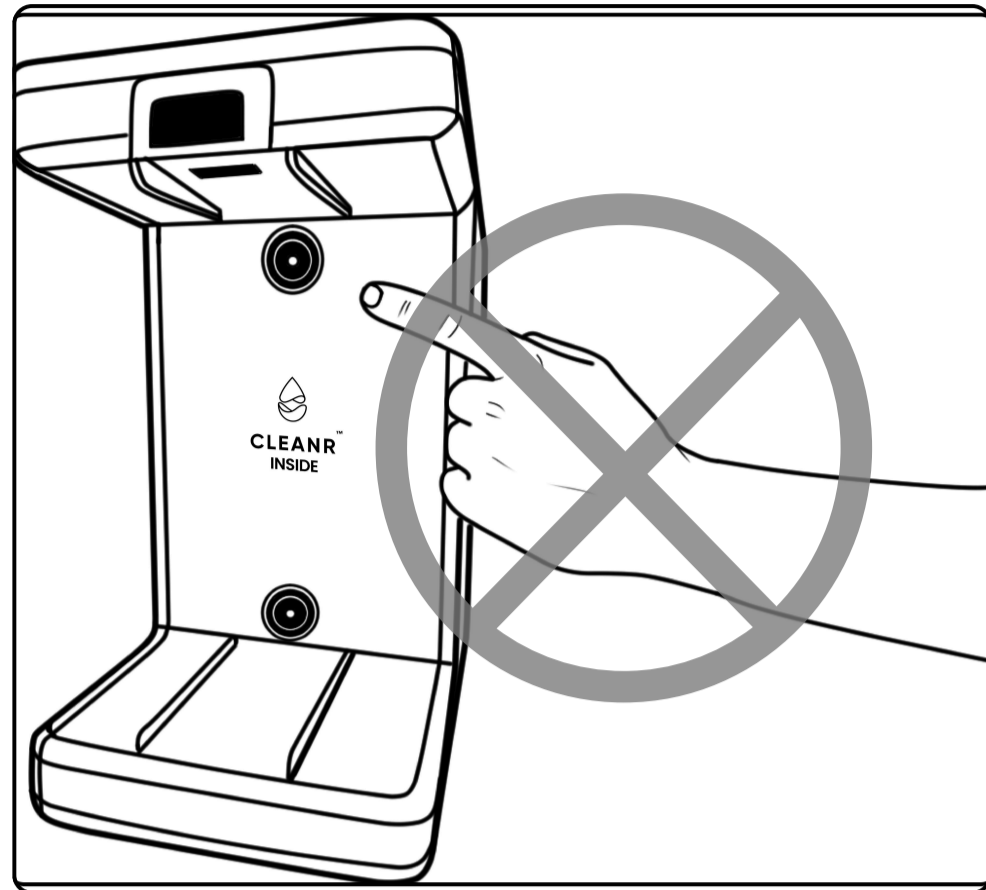

IMPORTANT: Located behind the canister on the front face of your Filter are two small round plates, each with a valve stem in the center. Do not push on these stems. If you push on a valve stem, water may escape from your Filter.

3. Insert a new CLEANR Pod

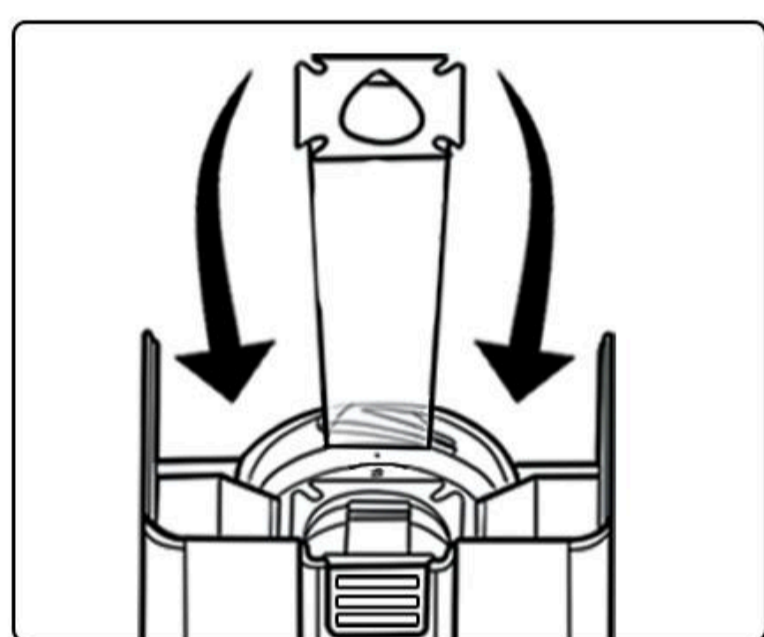

3a. Fit a new Pod into the canister, lining up the corners of the Pod with the notches in the canister until the face of the Pod sits flush with the top.

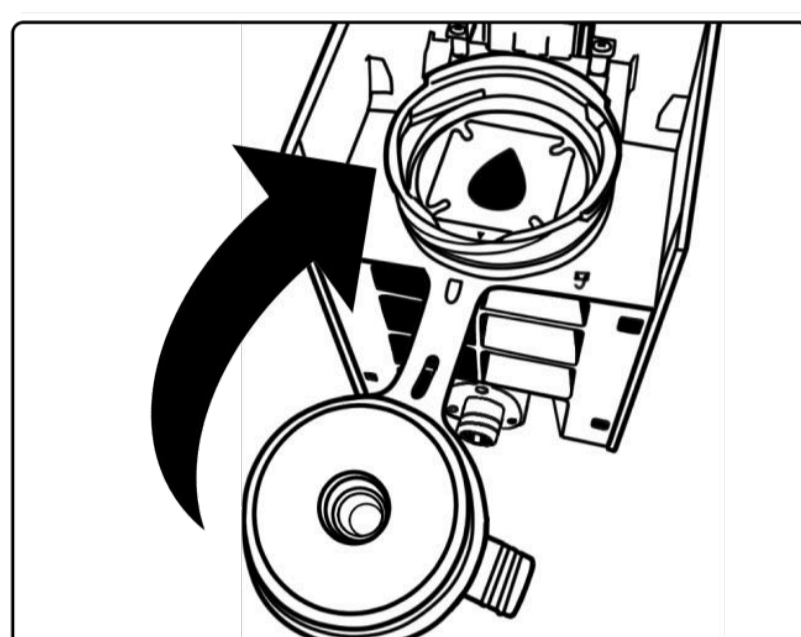

3b. Put the canister lid back onto the canister, positioning the alignment indicator on the canister lid to point to the UNLOCK symbol on the top of the canister.

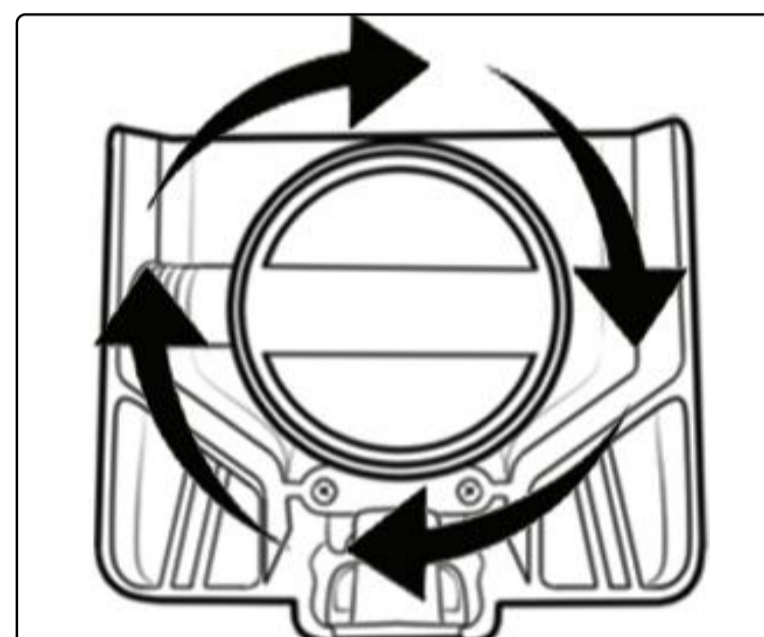

3c. Turn the canister lid clockwise until the alignment indicator on the canister lid points to the LOCK symbol on the canister and the canister lid will not turn any further.

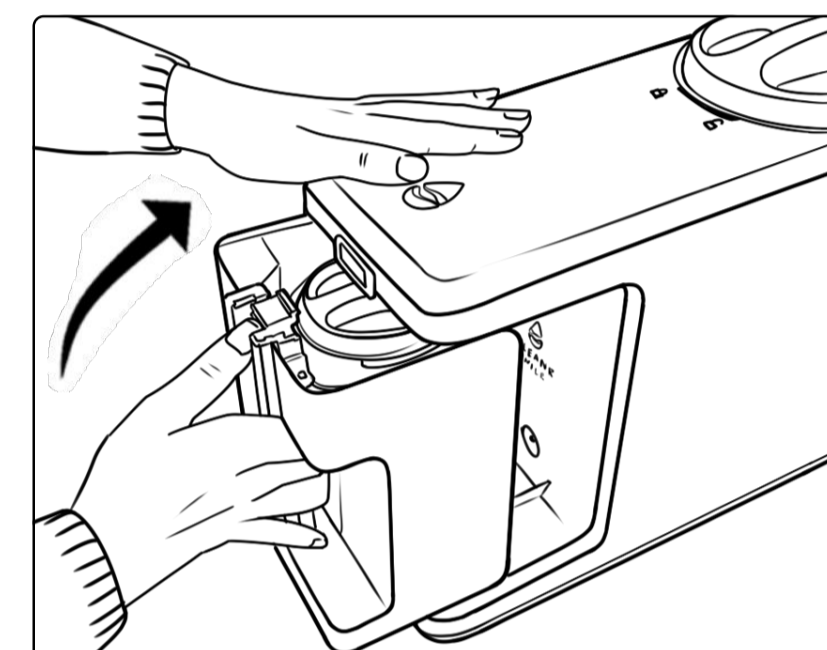

3d. Push the canister back into place until the canister locks into place.

Note that when the canister lid is on and the canister is fully locked into place, the blinking yellow Pod status indicator will turn off.

IMPORTANT: Remember to make sure the canister lid is in place to prevent water from leaking out of your Filter. If the canister lid is not properly in place, it is possible for washing machine drain water to escape from your Filter.

Cleaning the CLEANR VORTX

Under typical residential household conditions, the CLEANR™ VORTX will need to be cleaned one to two times per month, depending on the size of and fabric types in your laundry loads. Different types of fabric “shed” different amounts of microplastics and other fibers. Households with pets and / or with a noticeable amount of pet hair in or on laundered items will tend to need to clean the VORTX more frequently.



Clean the VORTX when the VORTX status icon illuminates with a solid yellow light.

1. Scan this QR code with your smart phone to see a video with an overview of cleaning the VORTX.



IMPORTANT: Cleaning the VORTX Filter should ONLY be performed in between washing machine cycles. If the VORTX Cleaning process is started while the machine is running, it is possible for washing machine drain water to escape from your Filter.

IMPORTANT: Wait 30-45 minutes after the wash cycle to access the VORTX Filter as components may be hot.

IMPORTANT: When cleaning the VORTX Filter, it is recommended to wear plastic gloves to avoid bacteria contamination from your Filtered material.

Maintenance of Your Filter

Cleaning the VORTX

2. Removal of the VORTX from your Filter

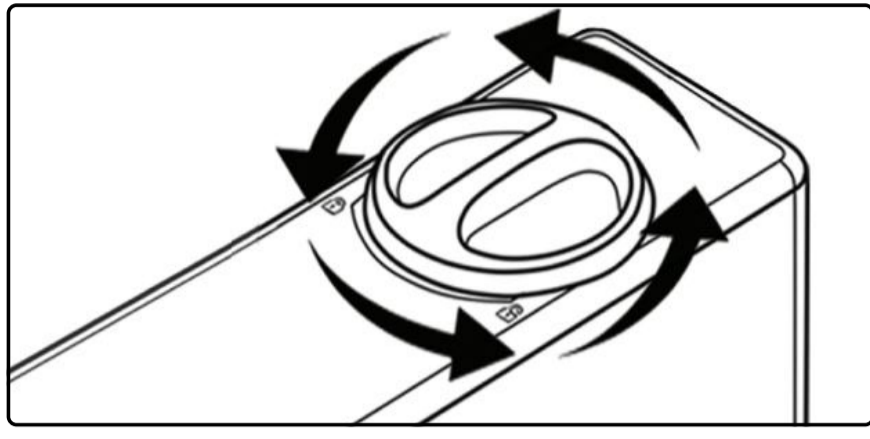

2a. Remove the top lid of your Filter by twisting the top lid counterclockwise, following the icons from locked to unlocked. Then, lift the top lid up to reveal the VORTX Filter inside the Filter chamber.

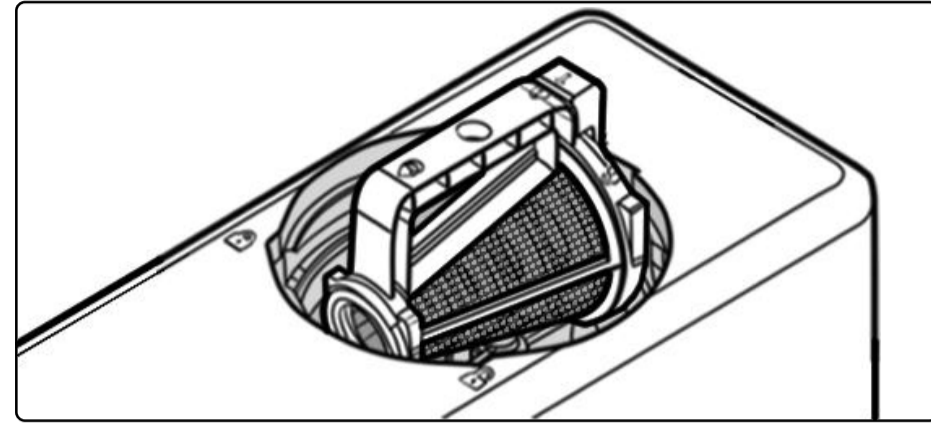

2b. Using the handle on the sleeve, remove the VORTX from your Filter.

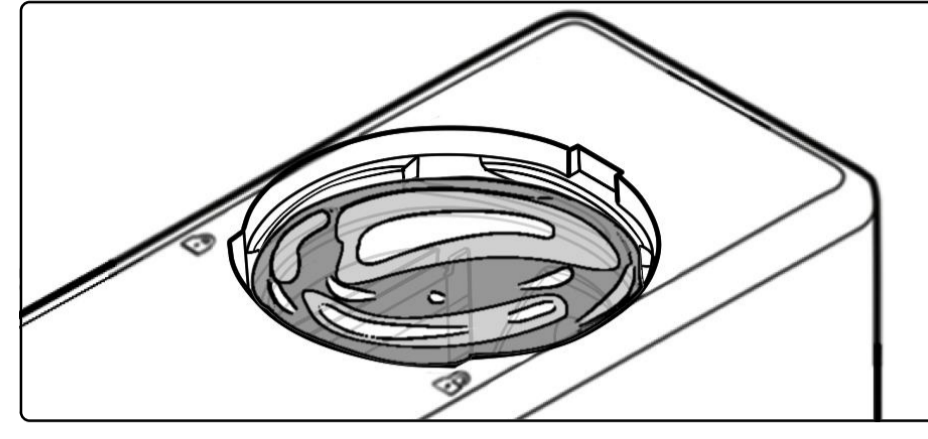

Note: It is normal to see water in the filter chamber after a wash cycle is complete. This ensures the VORTX maintains its ability to be cleaned, and the handle of the VORTX will always protrude out of the water for easy access.

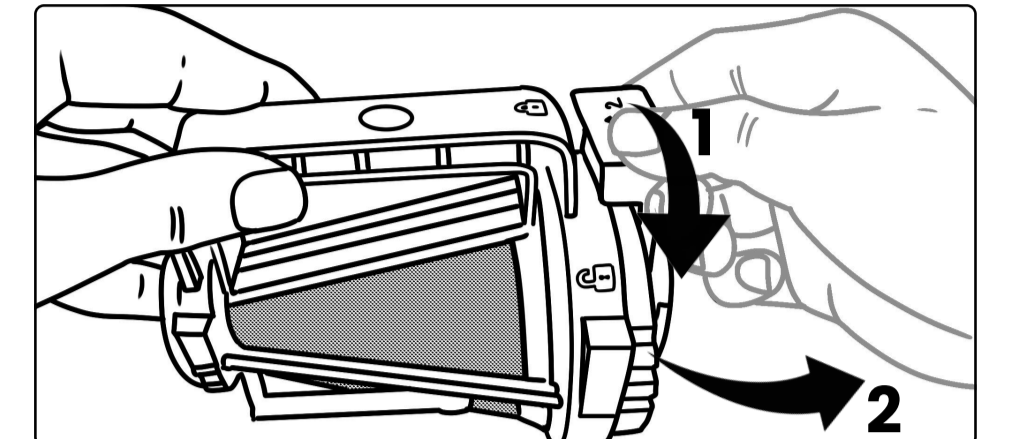

2c. Hold the VORTX Filter by the VORTX handle. Keep the sleeve in place and use the tab on the spiral to rotate the spiral counter clockwise, moving the arrow towards the UNLOCK symbol on the rim of the sleeve. Then pull the spiral out of the sleeve.

Note: When you remove the top lid, the VORTX light will blink yellow.

A cleaning regimen can be found on Page 14.

3. Residue Removal

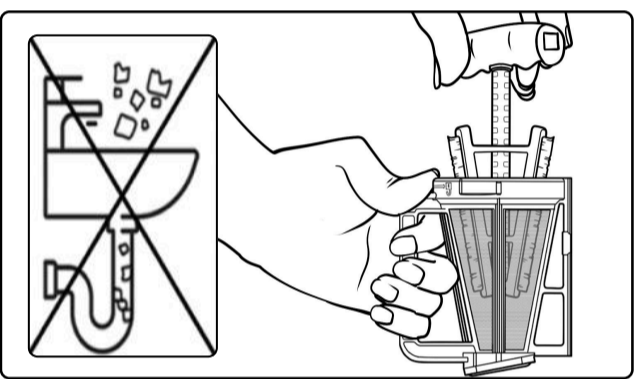

3a. Using the provided cleaning brush, brush the inside of the sleeve over a trash can by fitting the cleaning brush into the sleeve and rotating the brush two or three times inside the sleeve.

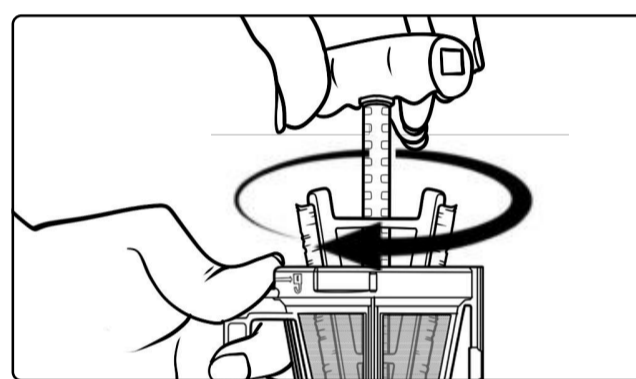

TIP: If the sleeve has a heavy covering of microplastics/debris, you may need to rotate the brush more than two or three times.

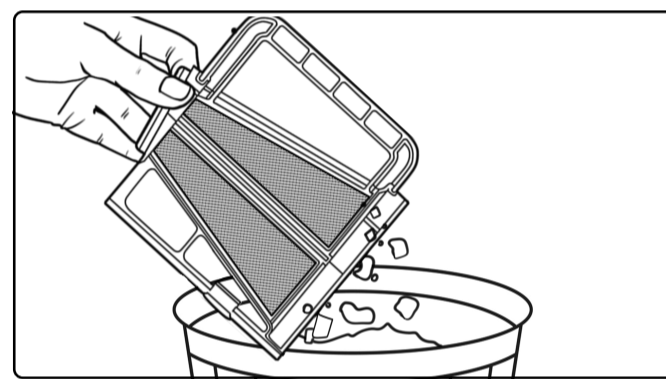

3b. Tap the brushed sleeve gently a few times on the side of the trash bin so that loose microplastics and other debris fall into the trash.

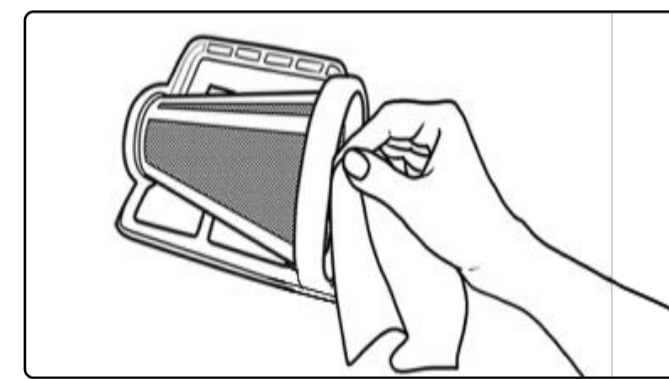

3c. Wipe the inside and outside of the sleeve with a towel to remove any visible microplastics / other captured materials that remain stuck to the sleeve.

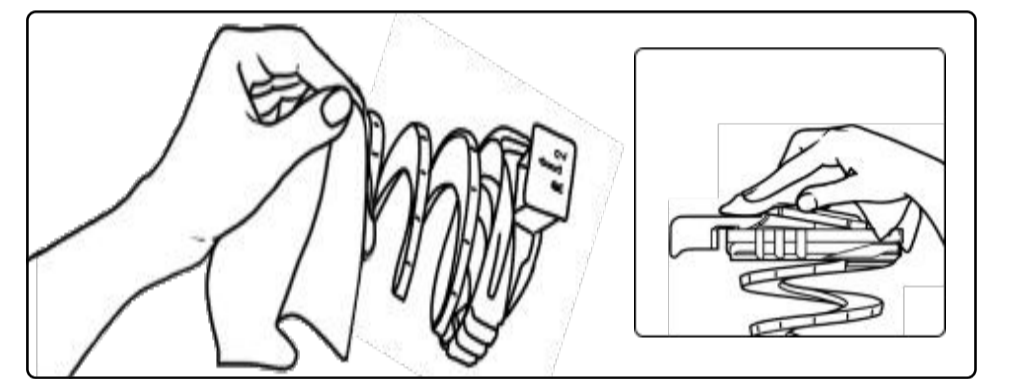

3d. Wipe the spiral and spiral rim with a towel to remove any visible microplastics/other materials that remain stuck to the spiral or the rim of the spiral.

IMPORTANT: Do not rinse the microplastics or debris from the VORTX Filter down the sewer or sink.

4. Re-insert the VORTX into your Filter

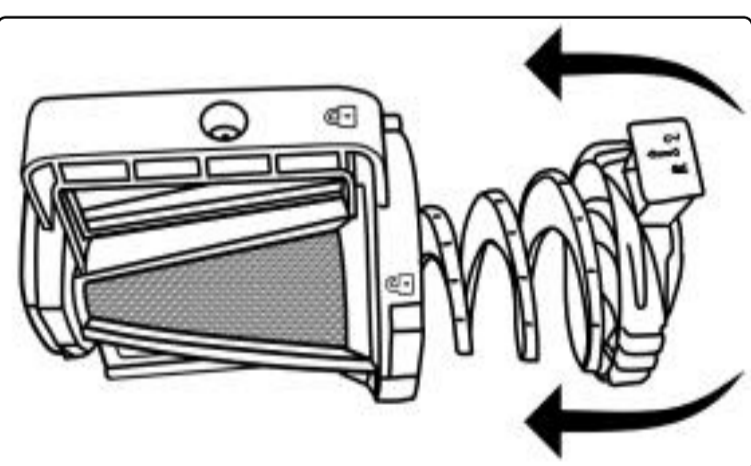

4a. Fit the spiral into the sleeve by holding the spiral by its tab and aligning the spiral arrow with the UNLOCK symbol on the rim of the sleeve.

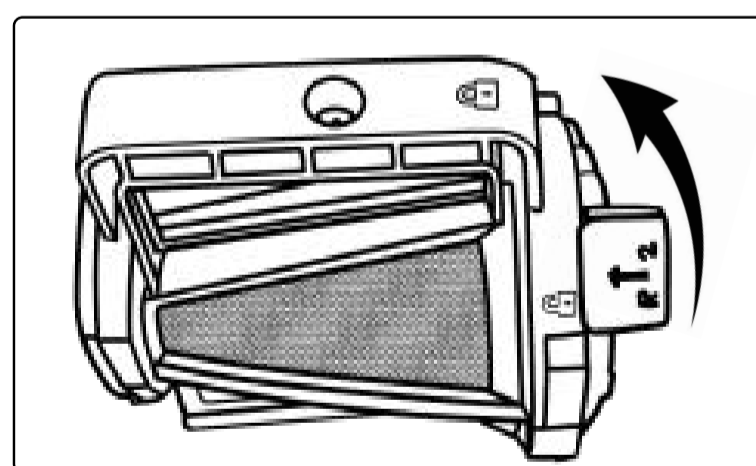

4b. Keep the sleeve in place and rotate the Spiral clockwise, moving the spiral tab in the direction of the LOCK symbol until the tab is fully aligned with the LOCK symbol.

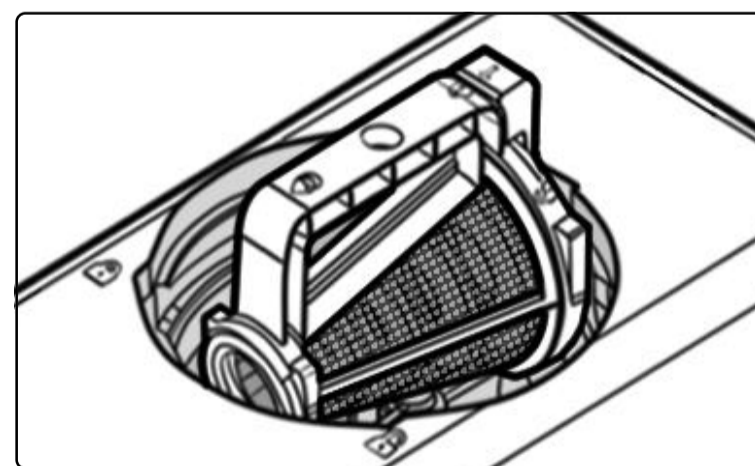

4c. Insert the VORTX Filter into the Filter chamber.

Note: It is not required to push the VORTX Filter into place.

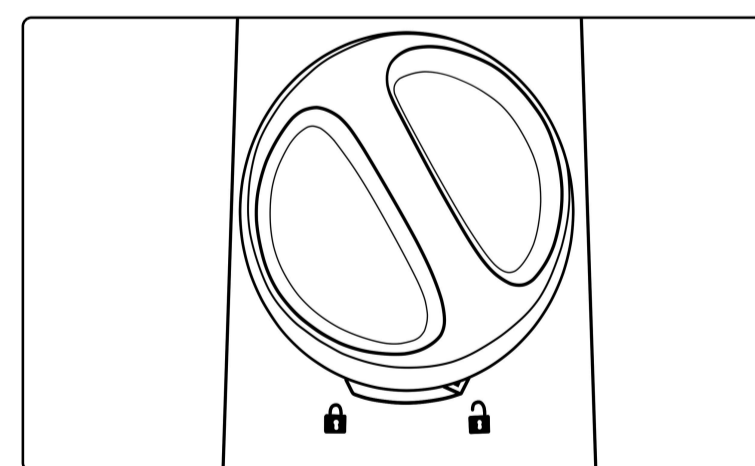

4d. Fit the Filter's top lid back into place on the top of the Filter, aligning the small pointed alignment indicator on the top lid with the UNLOCK symbol on the top of the Filter. Then turn the top lid clockwise, following the indicator from unlocked to locked.

When the VORTX is in place inside the Filter chamber and the top lid is in place, the blinking yellow VORTX light on the front of the Filter will turn off.

IMPORTANT: Remember to make sure the top lid is in place. If the top lid is not properly in place, it is possible for washing machine drain water to escape from your Filter.

Maintenance of Your Filter

Deep Cleaning Regimen

Under typical residential household conditions, a cleaning cycle is recommended around every month. The cleaning cycle will clean your washing machine and your Filter housing. While the App will notify users, this cleaning regimen can be performed more frequently if you experience an odor.

The CLEANR App will notify you when it is time to perform this regimen.

1. Ensure a new Pod is in Place

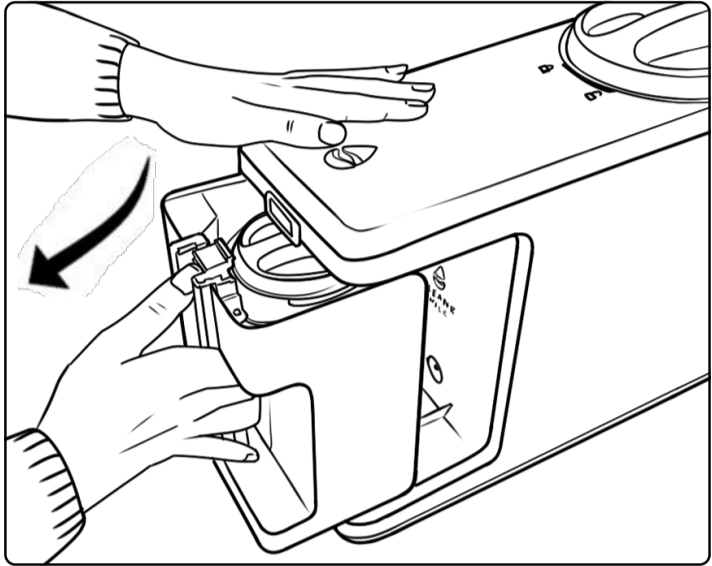

1a. Pull the canister out from your Filter.

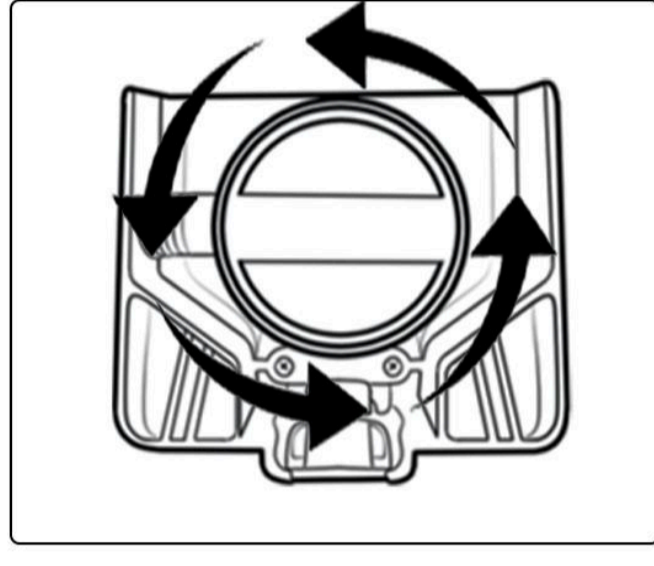

1b. Twist off the canister lid.

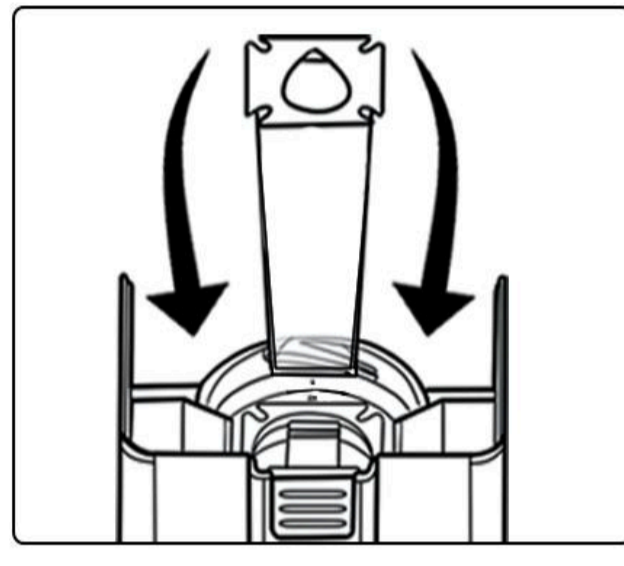

1c. Fit a new Pod into the canister.

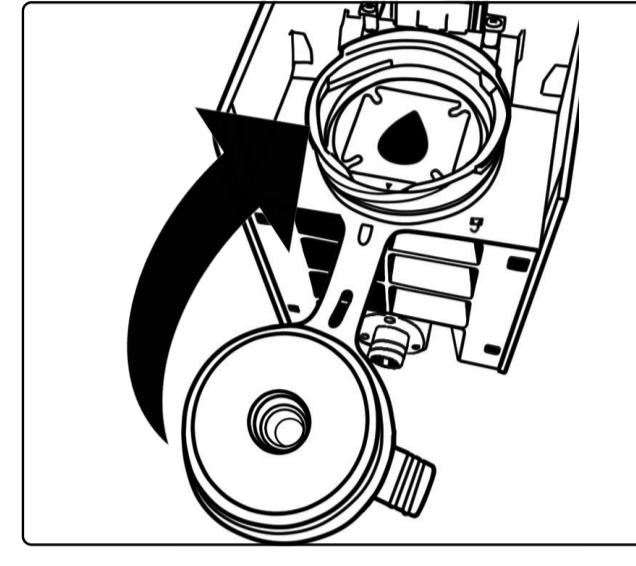

1d. Put the canister lid back onto the canister.

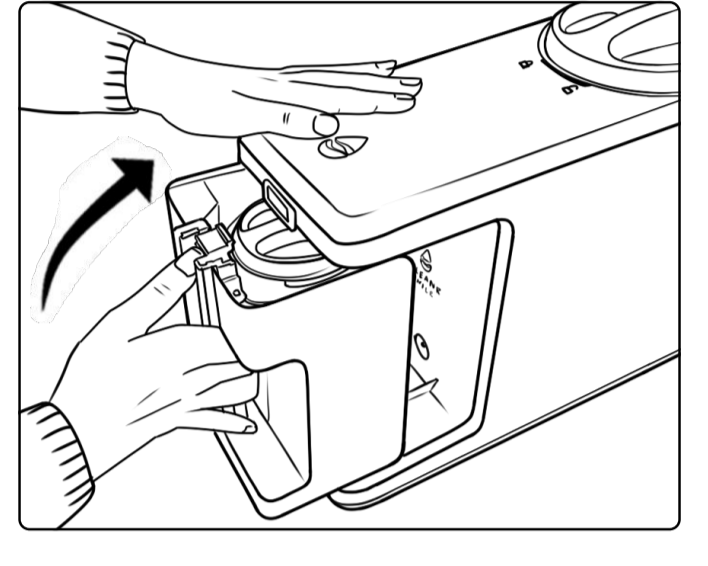

1e. Push the canister in until it locks back into place.

2. Removal of VORTX from your Filter

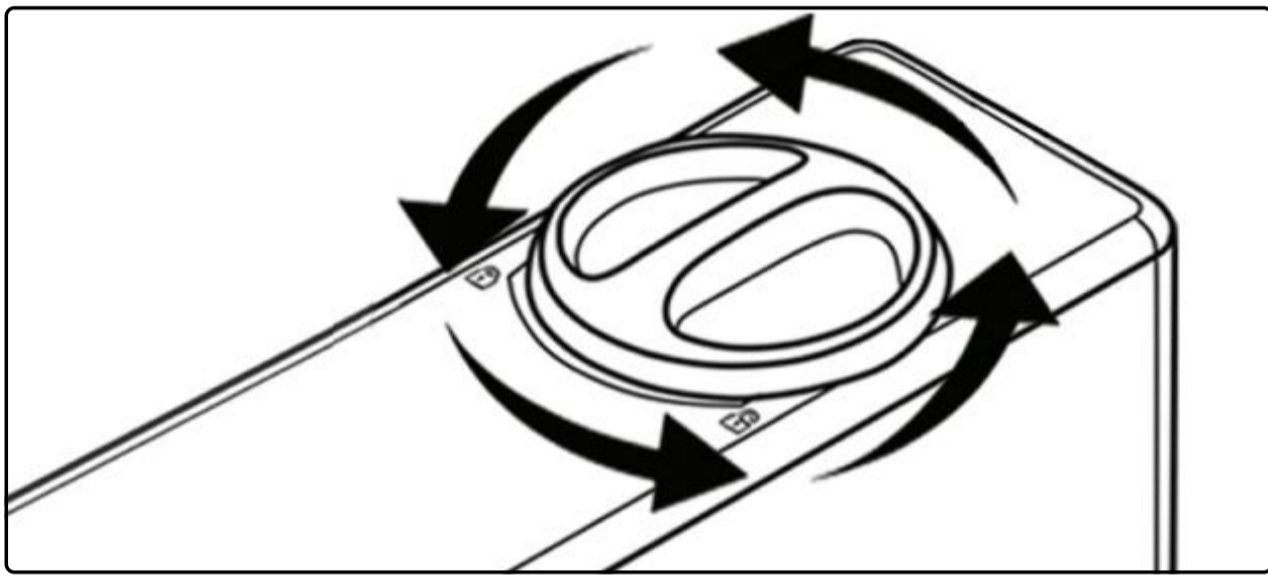

2a. Remove the top lid of your Filter.

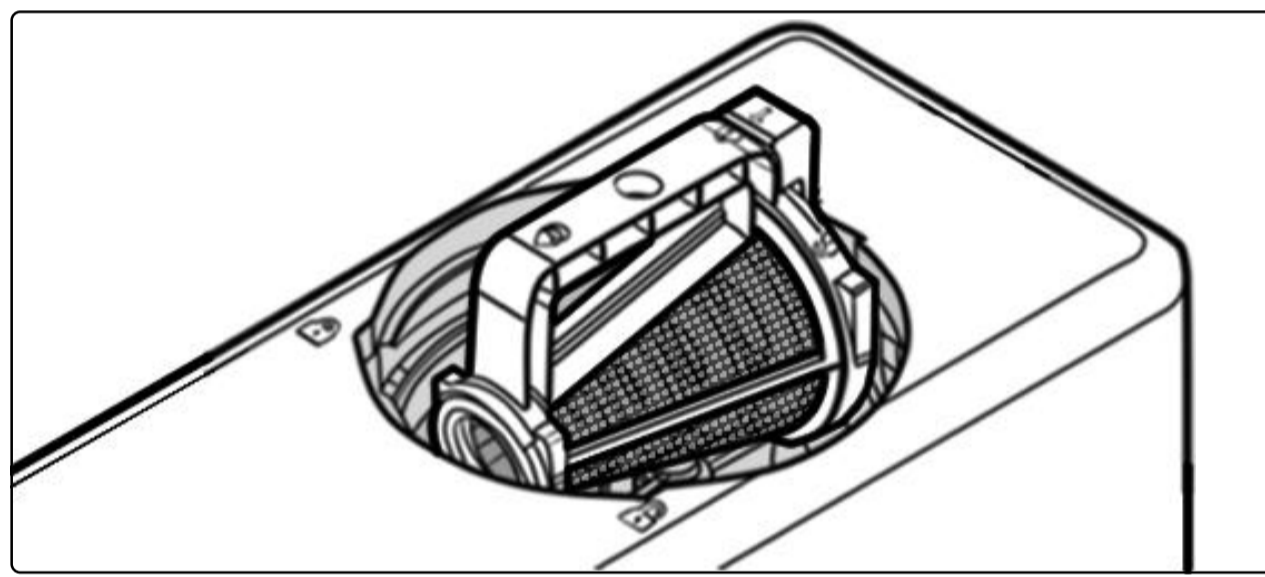

2b. Using the handle, remove the VORTX from the Filter chamber.

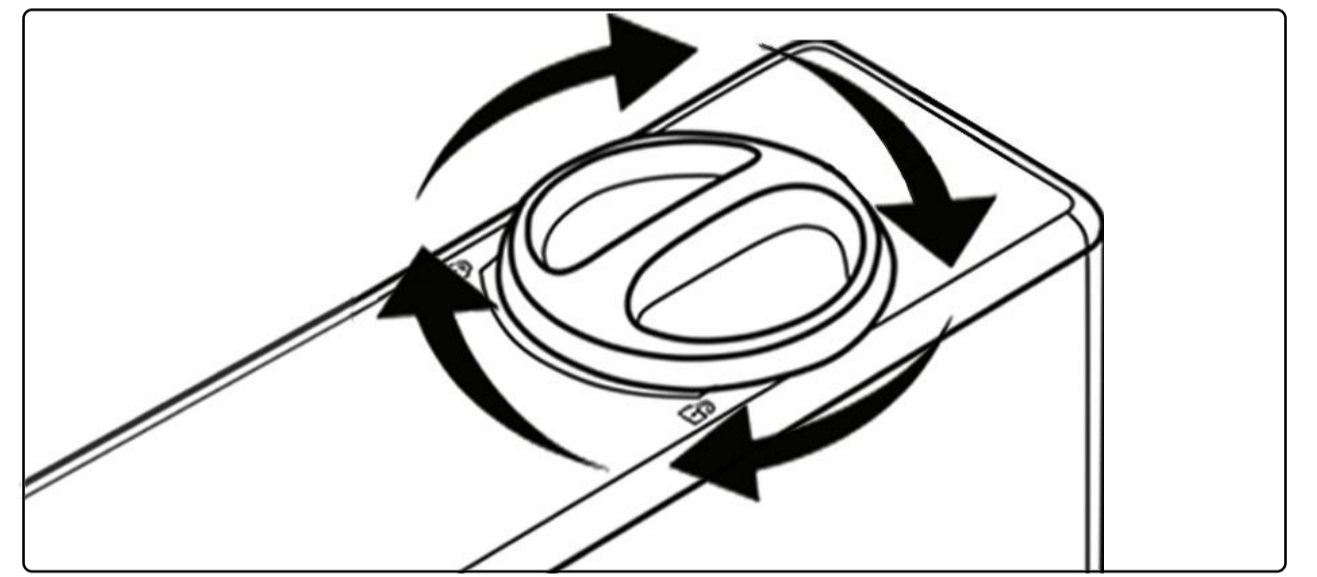

2c. Put your Filter's top lid back into place.

IMPORTANT: The VORTX light will blink yellow during this cycle because the VORTX Filter is out of place. This is normal. Be sure to put the VORTX Filter back in place after the cleaning cycle.

Note: Optional to keep VORTX in place if cleaned deeply prior to maintenance cycle.

Note: Additives and typical washing machine products and solutions may be used during this cycle.

3. Run an Empty Cleaning Cycle

3a. Remove all articles of clothing from the washing machine. The washing machine basin must be **empty**.

3b. In your drum or detergent drawer, it is recommended to use a **cleaning agent**. Bleach, washing machine cleaning products, detergent, or other cleaning products can be used. If you are unsure, please consult your washing machine guide for what additives are safe for the machine. It is also optional to include bleach or standard detergent directly in your CLEANR Filter.

3c. Select **your washing machine's cleaning cycle**. If cleaning cycle is not a setting, select any cycle with a hot temperature.

3d. Select the **highest water temperature**.

3e. **Start** the cycle.

4. Re-insert the CLEANR VORTX into your Filter

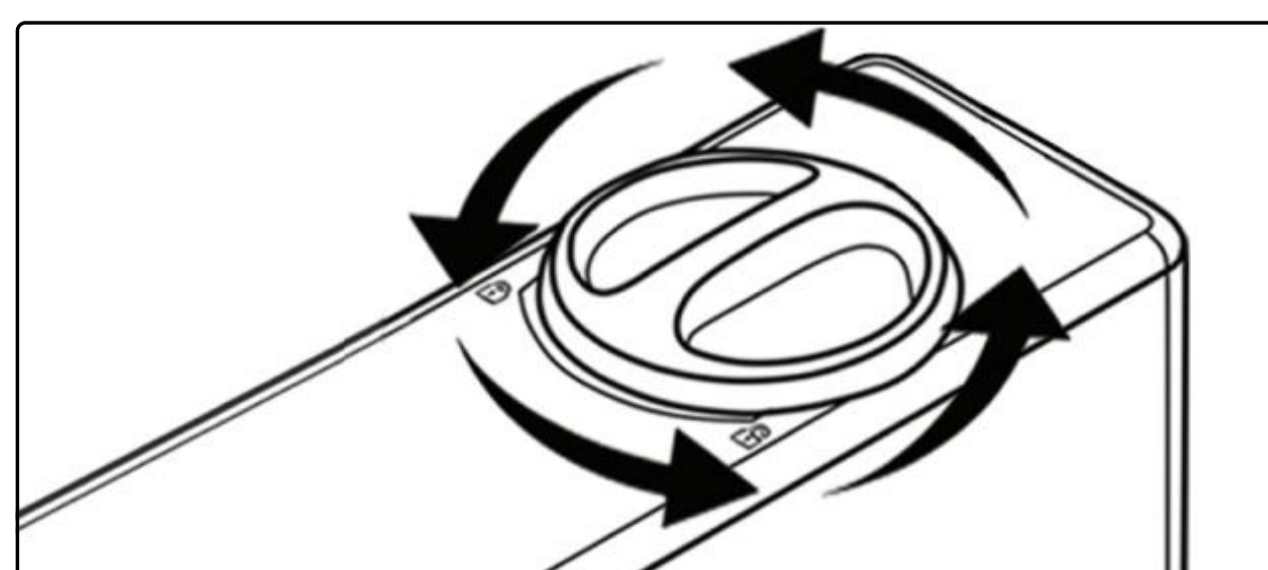

4a. After the cleaning cycle is complete, remove the top lid of your Filter.

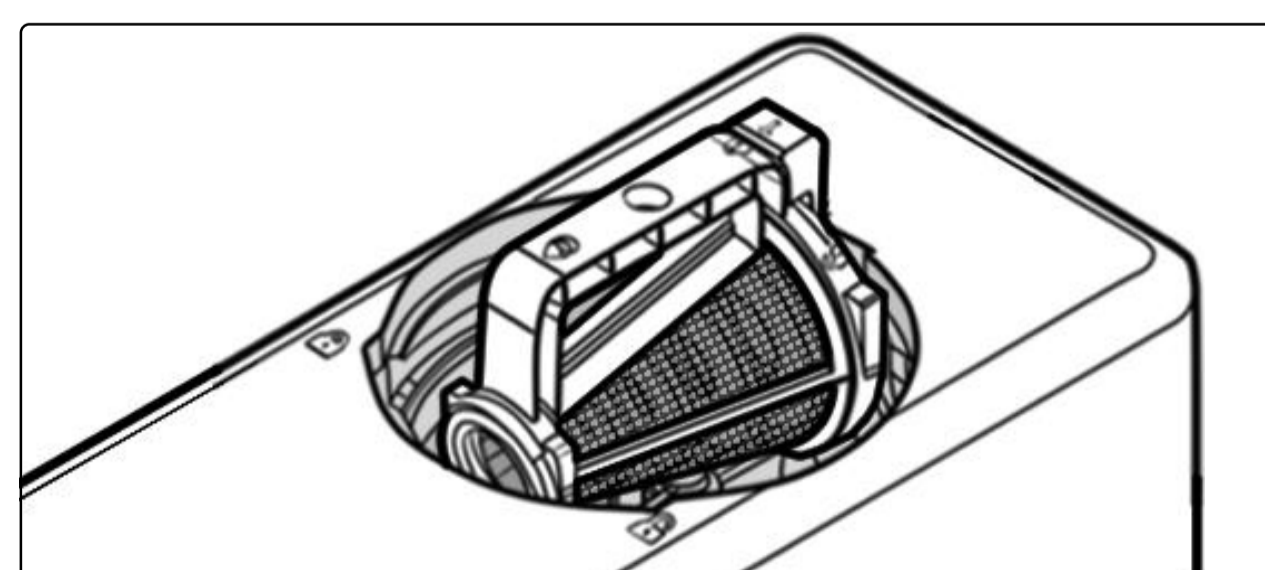

4b. Insert the VORTX in to the Filter chamber with the handle pointing up.

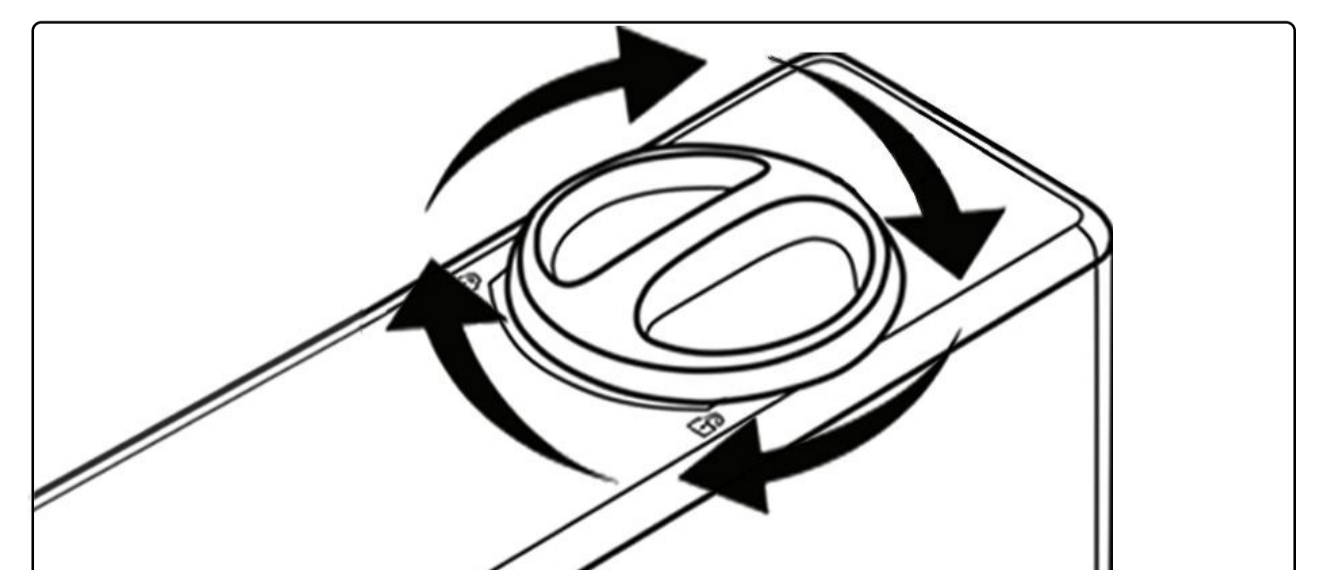



4c. Put your Filter's top lid back into place.

IMPORTANT: Ensure the cleaning cycle is complete before returning the VORTX its place in your Filter. Wait 30-45 minutes after the cleaning cycle to access your Filter as the components may be hot.

Troubleshooting & Support

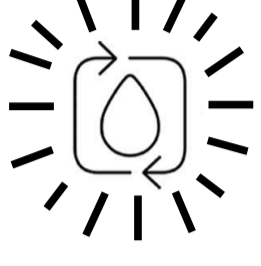
If you come across a problem while using your Filter, first check the table below and use the suggested solution to resolve the problem.

ERROR CONDITION	WHAT IT MEANS	HOW TO RESOLVE
Pod Status Light BLINKS RED 	Canister has been removed or is not fully locked into place while water is moving through your Filter. or Canister lid has been removed or is not fully locked into place while water is moving through your Filter.	<u>Pause the washing cycle.</u> Re-attach Canister immediately. Red blinking should stop, and logo will turn blue = ready to filter. The washing cycle can be resumed.
VORTX Status Light BLINKS RED 	Top lid has been removed or is not fully locked into place while water is moving through your Filter. or VORTX has been removed or is not fully locked into place while water is moving through your Filter.	<u>Pause the washing cycle.</u> Put top lid and VORTX back into place immediately. Red blinking should stop, and logo will turn blue = ready to filter. The washing cycle can be resumed.

SITUATION	HOW TO RESOLVE
Filter does not power on	Check that the power cord is properly plugged into the power jack on the back of your Filter. Check that the power cord is plugged into an electrical outlet and ensure that the electrical outlet has power. Press the On / Off switch on the top of your Filter.
VORTX chamber contains water after washing machine cycle completed	Sometimes residual water and particulate remains in your Filter after a washing machine cycle is complete; this is normal and will be pumped out later by your Filter. When removing the VORTX from the Filter chamber when there is residual water in the chamber, it may be helpful to hold the top lid underneath the VORTX, using the top lid to catch any water that may drip from the VORTX until you can place the assembly on a paper towel or other surface.
Pod full of water	Sometimes residual water remains inside the Pod after a washing machine cycle is complete; this is normal and does not mean your Filter is not working properly. You can dispose of the Pod with the water in it in the trash bin. Pending your Filter placement, leaving the Pod in the canister for around 60 minutes may allow it to fully drain. If needed, you can also pour the water into the basin of your washing machine. This will ensure that the water and any particles in the water are run back through your Filter during the next cycle. Do not empty the residual water into the sewer or sink.

Troubleshooting & Support

SITUATION	HOW TO RESOLVE
Cleaning lights remain on even after performing the suggested cleaning	This is likely to occur if the cleaning is performed while the filter is turned off. Your CLEANR Filter is designed to stay on for the entirety of the filter life, and must be turned on to register the cleaning. If the issue persists, contact CLEANR support.
Pod Status Icon indicated Pod change needed but Pod appears to be clean	This typically occurs when the laundry items washed are mostly white and / or very light in color, and the microfibers captured in the Pod are very similar to the color of the Pod material itself. Dispose the used Pod in the trash bin and replace with a new Pod.
Water leaks from hose	Perform the following checks: <ul style="list-style-type: none"> • Check that the hoses attached to your Filter inlet and outlet are both securely fastened. • Check that the drain hose from the washing machine is securely fastened. • Check that the drain hose from your Filter outlet to the laundry sewer is far enough down the laundry sewer so that drain water will not splash or leak near the opening. • Check that there are no kinks in the hoses and no obstructions to the hoses.
Water leaks when Canister is removed	From time to time you may notice a small amount of water appearing on the base of your Filter underneath the canister. Dry the water with a towel or paper towel and replace the canister as normal when ready.
Washing machine is reporting a drain error	First check to make sure your Filter is on and the blue light is illuminated. Next, check to see if the Pod needs to be changed or if the VORTX needs to be cleaned. If so, perform the proper Filter maintenance. If Filter maintenance does not resolve the drain error, then try the following procedure. Turn off the washing machine and your Filter. Remove the washing machine hose from the CLEANR Filter inlet connection. Check that the washing machine hose does not have any particle build-up. Then, check that the inlet of the CLEANR Filter is clear. If there appears to be a large ball of hair/fiber or a foreign object blocking the inlet, use tweezers to remove the obstruction. Re-attach the washing machine hose to the CLEANR Filter inlet connection. The washing machine should now be able to drain freely. If the above does not resolve the drain error, check the washing machine manual instructions to resolve the drain error.
Your Filter Activates when shaken.	If your Filter is shaken, it will activate the pump in your Filter and drain water properly out of the device, which is normal. If your Filter shakes during a cycle, ensure it is placed on a level surface.

Support

If the actions listed above do not resolve the problem or if you encounter a problem with your Filter not listed in the table above, please contact the support team by emailing support@cleanr.life or by visiting our support page at www.cleanr.life/support

Email:
support@cleanr.life

Support Page:
www.cleanr.life/support



